

# YAMAHA

# GX-5 Active Servo Technology

*Natural Sound Mini Component System*

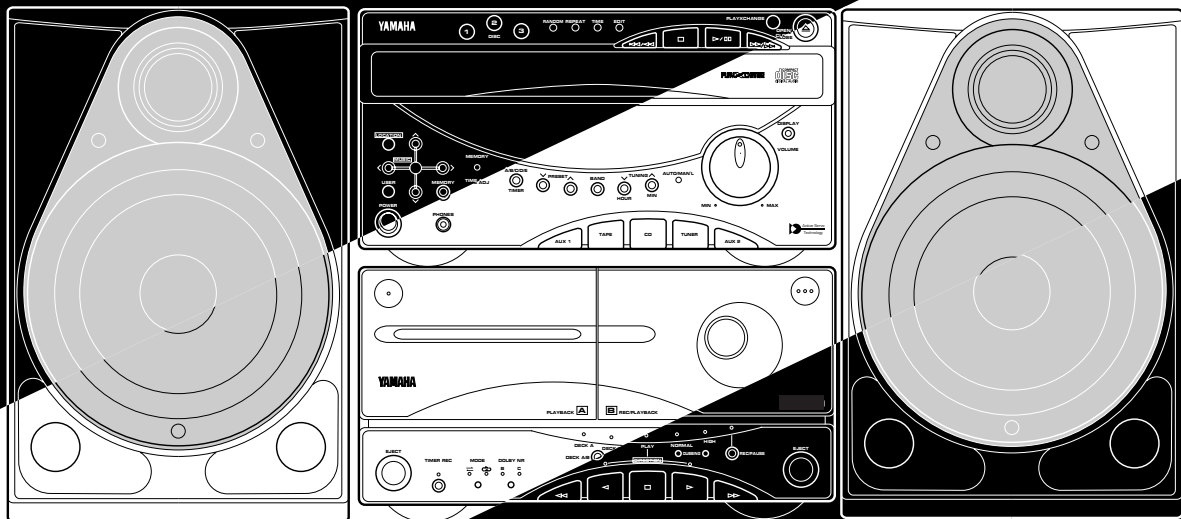

GX-5: TCD-GX5 + KMA-GX5 + NX-GX5

## OWNER'S MANUAL

# SAFETY INSTRUCTIONS

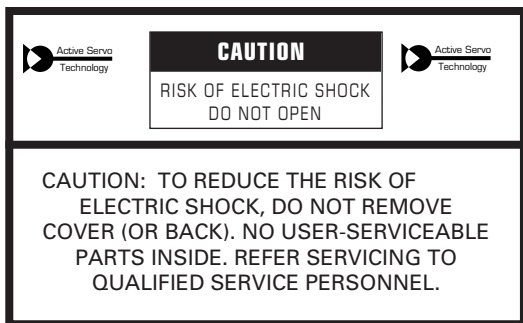

• Explanation of Graphical Symbols



The lightning flash with arrowhead symbol, within an equilateral triangle, is intended to alert you to the presence of uninsulated "dangerous voltage" within the product's enclosure that may be of sufficient magnitude to constitute a risk of electric shock to persons.



The exclamation point within an equilateral triangle is intended to alert you to the presence of important operating and maintenance (servicing) instructions in the literature accompanying the appliance.

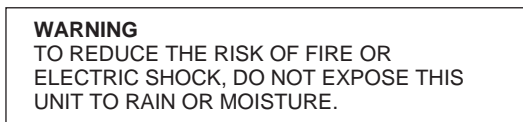

- 1 Read Instructions – All the safety and operating instructions should be read before the unit is operated.
  - 2 Retain Instructions – The safety and operating instructions should be retained for future reference.
  - 3 Heed Warnings – All warnings on the unit and in the operating instructions should be adhered to.
  - 4 Follow Instructions – All operating and other instructions should be followed.
  - 5 Water and Moisture – The unit should not be used near water – for example, near a bathtub, washbowl, kitchen sink, laundry tub, in a wet basement, or near a swimming pool, etc.
  - 6 Carts and Stands – The unit should be used only with a cart or stand that is recommended by the manufacturer.
  - 6A A unit and cart combination should be moved with care. Quick stops, excessive force, and uneven surfaces may cause the unit and cart combination to overturn.
- 

- 7 Wall or Ceiling Mounting – The unit should be mounted to a wall or ceiling only as recommended by the manufacturer.
- 8 Ventilation – The unit should be situated so that its location or position does not interfere with its proper ventilation. For example, the unit should not be situated on a bed, sofa, rug, or similar surface, that may block the ventilation openings; or placed in a built-in installation, such as a bookcase or cabinet that may impede the flow of air through the ventilation openings.
- 9 Heat – The unit should be situated away from heat sources such as radiators, stoves, or other appliances that produce heat.
- 10 Power Sources – The unit should be connected to a power supply only of the type described in the operating instructions or as marked on the unit.
- 11 Power-Cord Protection – Power-supply cords should be routed so that they are not likely to be walked on or pinched by items placed upon or against them, paying particular attention to cords at plugs, convenience receptacles, and the point where they exit from the unit.
- 12 Cleaning – The unit should be cleaned only as recommended by the manufacturer.
- 13 Nonuse Periods – The power cord of the unit should be unplugged from the outlet when left unused for a long period of time.
- 14 Object and Liquid Entry – Care should be taken so that objects do not fall into and liquids are not spilled into the inside of the unit.
- 15 Damage Requiring Service – The unit should be serviced by qualified service personnel when:
  - A. The power-supply cord or the plug has been damaged; or
  - B. Objects have fallen, or liquid has been spilled into the unit; or
  - C. The unit has been exposed to rain; or
  - D. The unit does not appear to operate normally or exhibits a marked change in performance; or
  - E. The unit has been dropped, or the cabinet damaged.
- 16 Servicing – The user should not attempt to service the unit beyond those means described in the operating instructions. All other servicing should be referred to qualified service personnel.
- 17 Power Lines – An outdoor antenna should be located away from power lines.
- 18 Grounding or Polarization – Precautions should be taken so that the grounding or polarization is not defeated.

- 19 Outdoor Antenna Grounding** – If an outside antenna is connected to this unit, be sure the antenna system is grounded so as to provide some protection against voltage surges and built-up static charges. Article 810 of the National Electrical Code, ANSI/NFPA 70, provides information with regard to proper grounding of the mast and supporting structure, grounding of the lead-in wire to an antenna discharge unit, size of grounding conductors, location of antenna discharge unit, connection to grounding electrodes, and requirements for the grounding electrode.

EXAMPLE OF ANTENNA GROUNDING

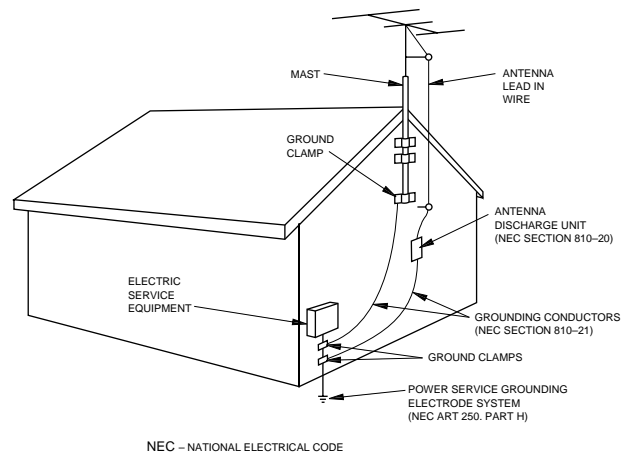

**Note to CATV system installer:**

This reminder is provided to call the CATV system installer's attention to Article 820-40 of the NEC that provides guidelines for proper grounding and, in particular, specifies that the cable ground shall be connected to the grounding system of the building, as close to the point of cable entry as practical.

**SPECIAL NOTES FOR FCC COMPOSITE DEVICE**

This device is a composite system. The digital device component may not cause harmful interference.

**FCC INFORMATION**

**1. IMPORTANT NOTICE : DO NOT MODIFY THIS UNIT!**

This product, when installed as indicated in the instructions contained in this manual, meets FCC requirements. Modifications not expressly approved by Yamaha may void your authority, granted by the FCC, to use the product.

**2. IMPORTANT :** When connecting this product to accessories and/or another product use only high quality shielded cables. Cable/s supplied with this product **MUST** be used. Follow all installation instructions. Failure to follow instructions could void your FCC authorization to use this product in the USA.

**3. NOTE :** This product has been tested and found to comply with the requirements listed in FCC Regulations, Part 15 for Class "B" digital devices. Compliance with these requirements provides a reasonable level of assurance that your use of this product in a residential environment will not result in harmful interference with other electronic devices.

This equipment generates/uses radio frequencies and, if not installed and used according to the instructions found in the users manual, may cause interference harmful to the operation of other electronic devices.

Compliance with FCC regulations does not guarantee that interference will not occur in all installations. If this product is found to be the source of interference, which can be determined by turning the unit "OFF" and "ON", please try to eliminate the problem by using one of the following measures:

Relocate either this product or the device that is being affected by the interference.

Utilize power outlets that are on different branch (circuit breaker or fuse) circuits or install AC line filter/s.

In the case of radio or TV interference, relocate/reorient the antenna. If the antenna lead-in is 300 ohm ribbon lead, change the lead-in to coaxial type cable.

If these corrective measures do not produce satisfactory results, please contact the local retailer authorized to distribute this type of product. If you can not locate the appropriate retailer, please contact Yamaha Electronics Corp., U.S.A. 6660 Orangethorpe Ave, Buena Park, CA 90620.

The above statements apply **ONLY** to those products distributed by Yamaha Corporation of America or its subsidiaries.

# We Want You Listening For A Lifetime

YAMAHA and the Electronic Industries Association's Consumer Electronics Group want you to get the most out of your equipment by playing it at a safe level. One that lets the sound come through loud and clear without annoying blaring or distortion – and, most importantly, without affecting your sensitive hearing.

Since hearing damage from loud sounds is often undetectable until it is too late, YAMAHA and the Electronic Industries Association's Consumer Electronics Group recommend you to avoid prolonged exposure from excessive volume levels.



## SUPPLIED ACCESSORIES

• After unpacking, check that the following parts are included.

- Remote control transmitter

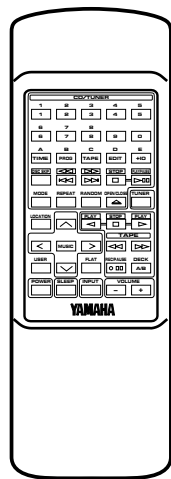

- AM (MW/LW) loop antenna

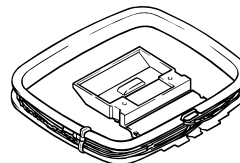

- Indoor FM antenna

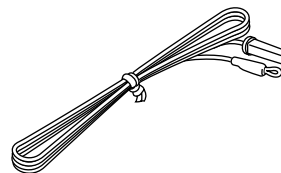

- Batteries (size AA, UM/SUM-3, R6, HP-7)

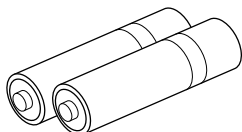

- Speaker cords

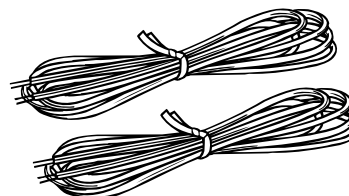

1 TCD-GX5

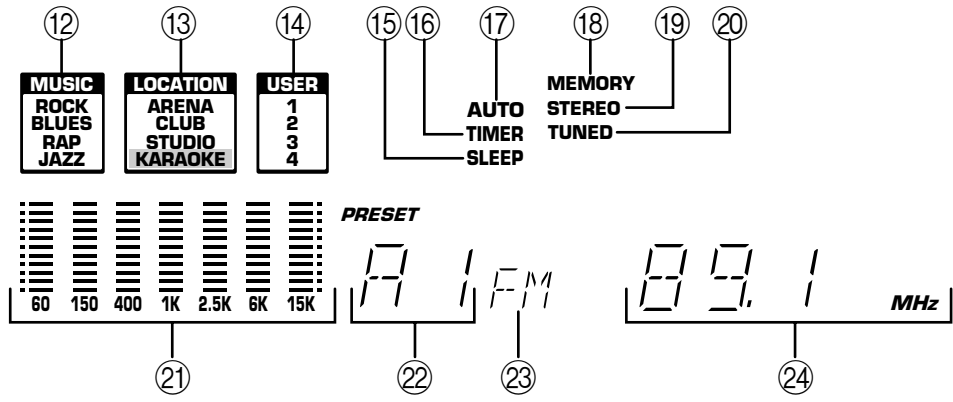
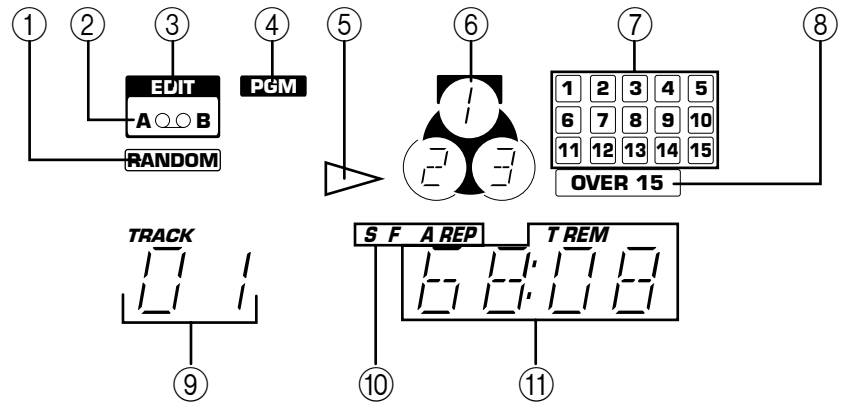
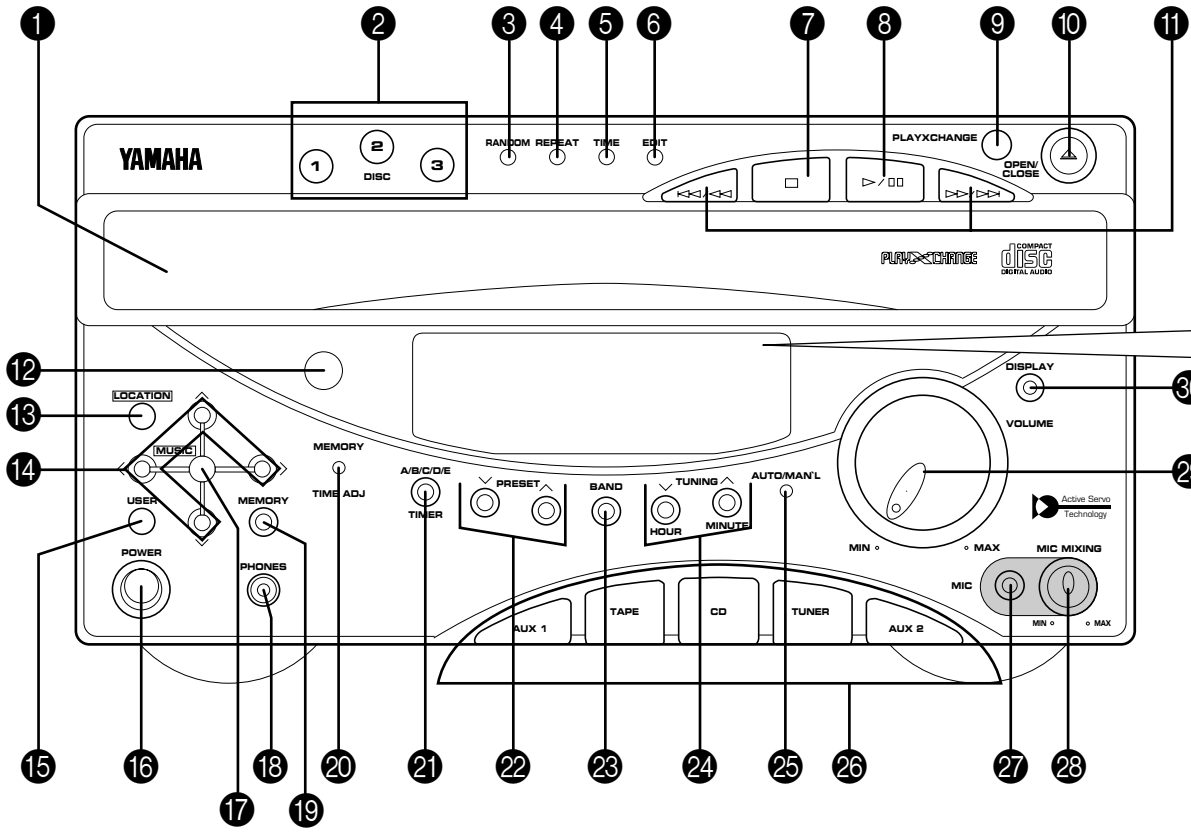

2 **KMA-GX5**

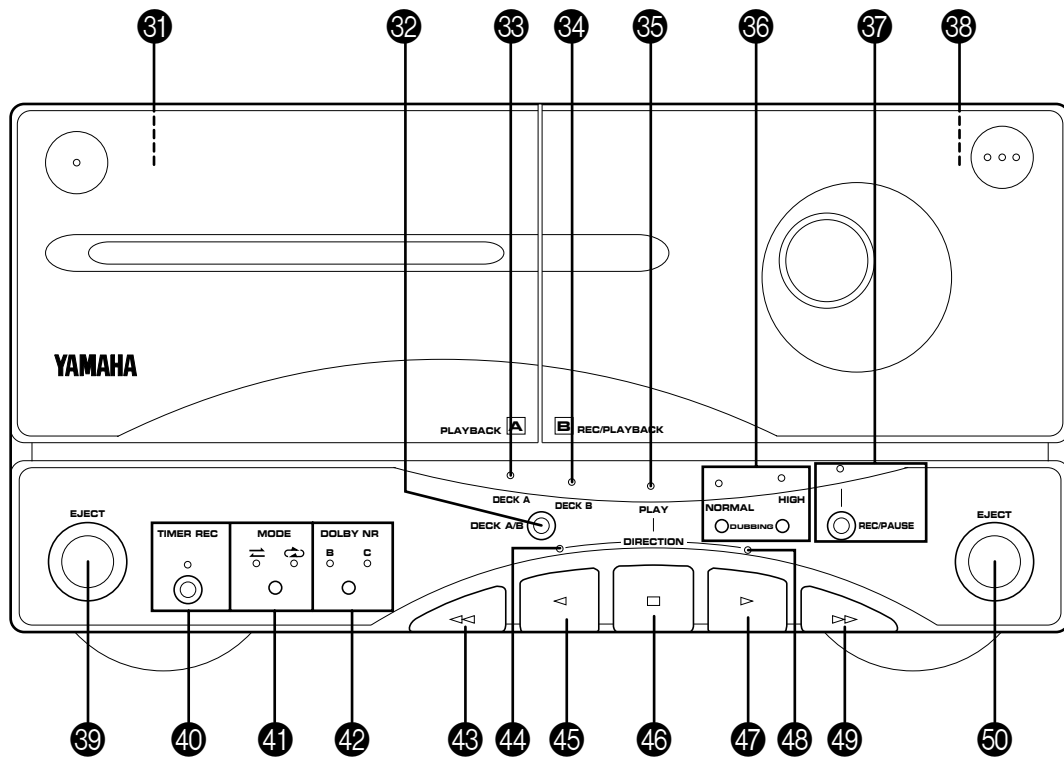

3 **NX-GX5**

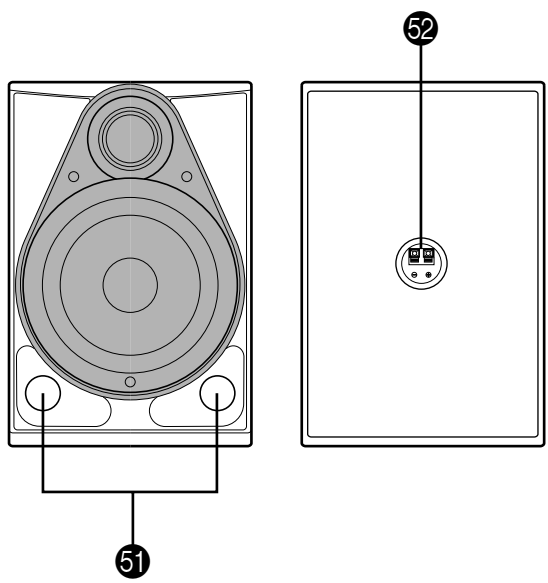

4

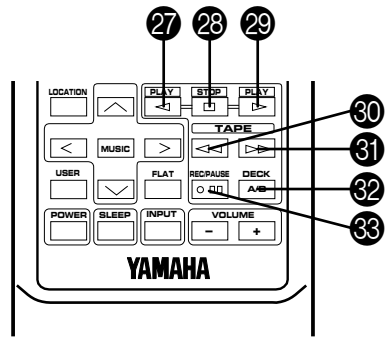
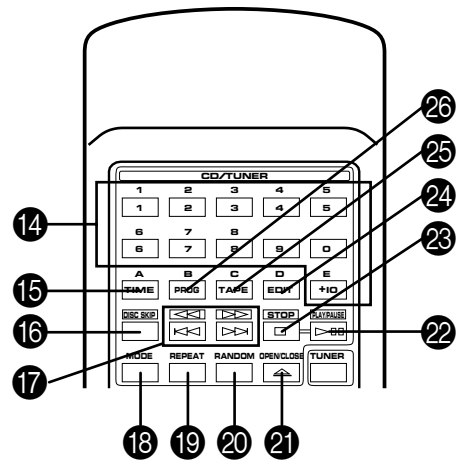
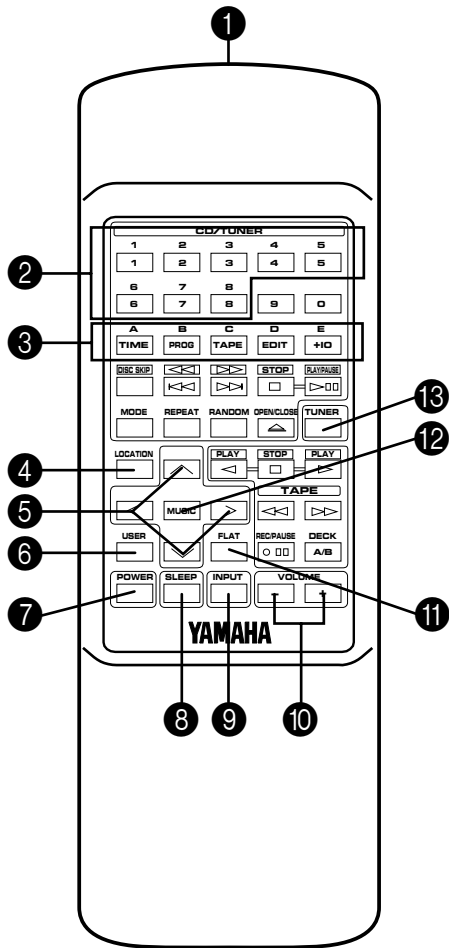

5

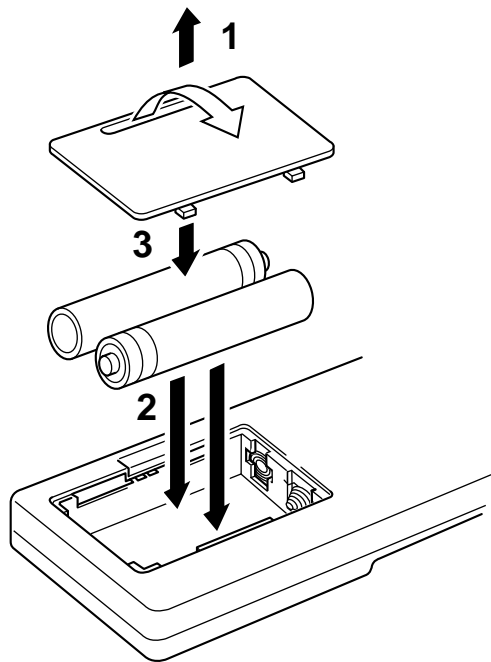

6

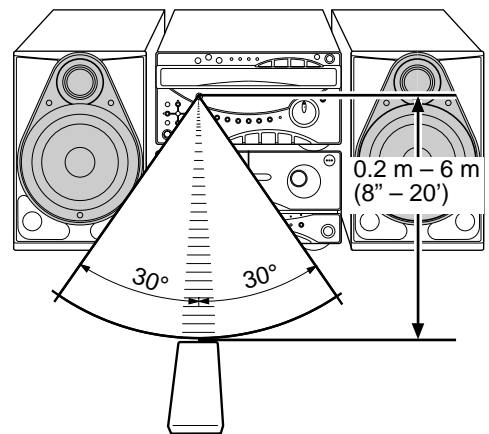

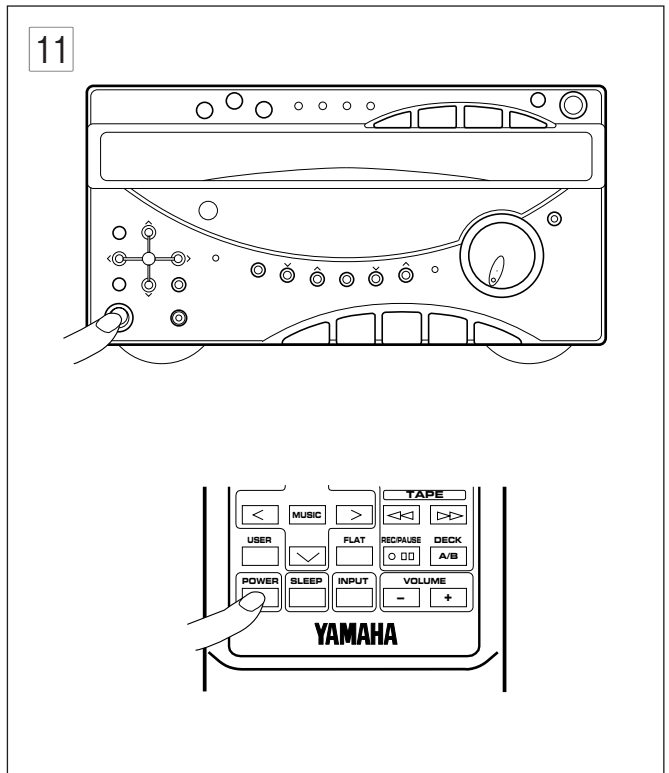
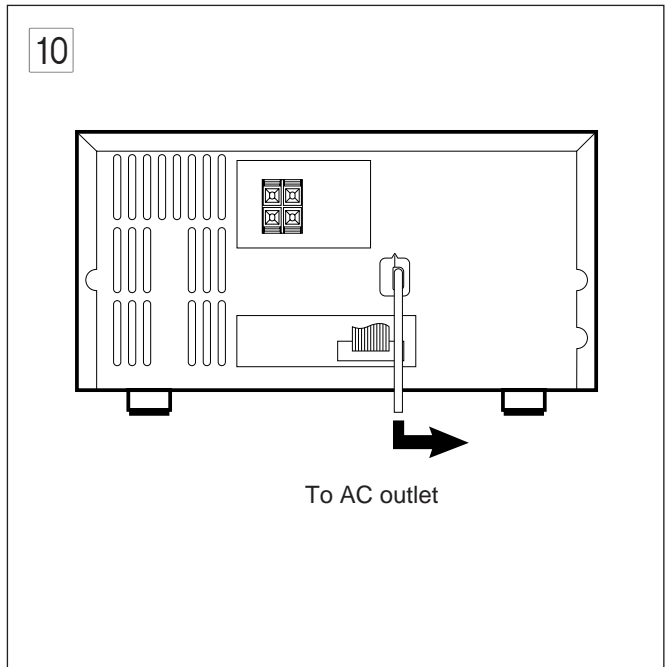
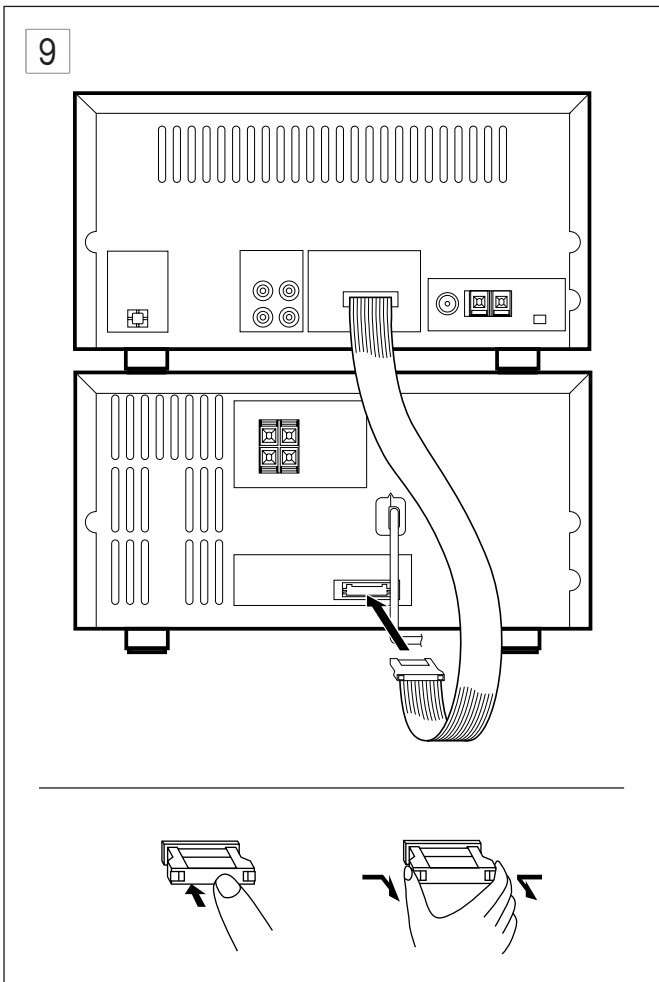
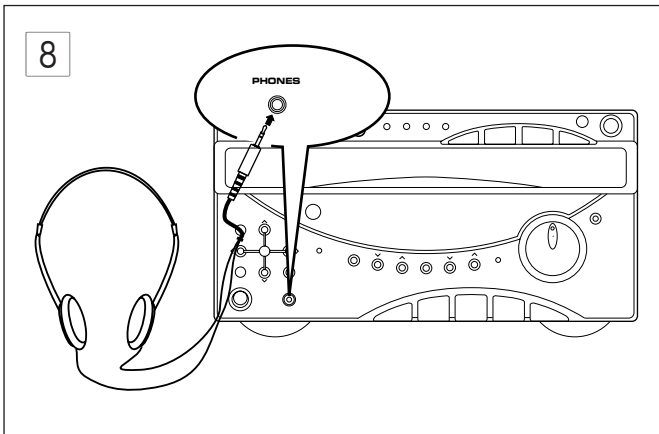
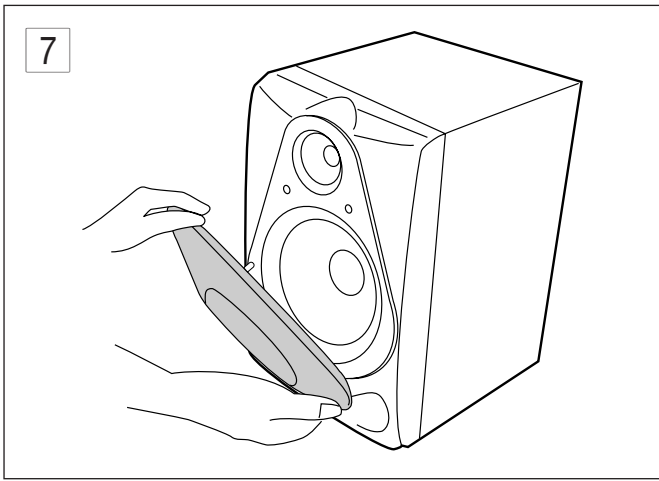



## INTRODUCTION

Thank you for purchasing this YAMAHA product. We hope it will give you many years of trouble-free enjoyment. For the best performance, read this manual carefully. It will guide you in operating your YAMAHA product.

## FEATURES

- 50W + 50W (6Ω) Output Power, 10% THD, 1 kHz
- 4 Preset Graphic Equalizer Modes Selectable According to the Music Source
- 3-Mode Sound Field Processor (4-Modes for Australia, Singapore and General Models Only)
- 4-Pairs of Equalizer and Sound Field Mode Storing Capability
- Microphone Jack and Mixing Level Control for Karaoke (Australia, Singapore and General Models Only)
- Random Access Programmable CD Playback
- Single Track/Entire Disc/All Disc Repeat Play
- Random-sequence Play
- Automatic Synchronized Recording with CD Playback
- Automatic CD Editing Function for Recording to Tape
- Double Cassette Tape Deck with Automatic Reversing Function
- 2-Way Speed Dubbing
- Dolby B/C Noise Reduction System
- 40 Station Automatic Preset Tuning
- Multi-Use Timer/Sleep Timer
- Active Servo Processing Speaker System (NX-GX5)
- Remote Control Capability

## CONTENTS

	Page		Page
PRECAUTIONS .....	2-3	TAPE DECK OPERATION .....	20-23
PLACING THE SYSTEM .....	3	RECORDING COMPACT DISCS .....	24-29
NAMES OF CONTROLS AND INDICATORS .....	4-5	OTHER RECORDINGS.....	30-31
REMOTE CONTROL TRANSMITTER.....	5-6	GRAPHIC EQUALIZER/SOUND FIELD PROCESSOR CONTROL.....	32-36
REMOVING THE FRONT GRILLE .....	6	KARAOKE OPERATION (Australia, Singapore and General models only).....	37
LISTENING WITH HEADPHONES.....	6	HOW TO USE THE BUILT-IN TIMER.....	38-41
CONNECTIONS.....	7-8	CONNECTING EXTERNAL UNITS .....	42
TURNING THE POWER ON/OFF TO THIS SYSTEM.....	8	MAINTENANCE .....	42
SETTING THE CLOCK .....	9	TROUBLESHOOTING .....	43
VOLUME CONTROL.....	9	SPECIFICATIONS.....	44
COMPACT DISC PLAYER OPERATION.....	10-16		
TUNING OPERATION .....	17-19		

For basic source play, the following illustrations on top of pages will help you to look for the section you need.



.....CD playback



.....Tuning



.....Tape playback/recording

## PRECAUTIONS: READ THIS BEFORE OPERATING YOUR UNIT

- To assure the finest performance, please read this manual carefully. Keep it in a safe place for future reference.
- This system is equipped with the newly developed Active Servo Processing Speaker System. It is not designed for use with conventional speakers. Therefore, **do not attempt to connect other speakers than the provided speaker system.**
- Choose the installation location of this unit carefully. Avoid placing it in direct sunlight or close to a source of heat. Also avoid locations subject to vibration and excessive dust, heat, cold or moisture. Keep it away from sources of hum such as transformers and electric motors.
- Do not operate this unit upside-down. It may overheat, possibly causing damage.
- Never open the cabinet. If something drops into the set, contact your dealer.
- The openings on the cabinet assure proper ventilation of the unit. If these openings are obstructed, the temperature inside the cabinet will rise rapidly and eventually damage the circuits. Therefore, avoid placing objects against these openings and do not install the unit where the flow of air through the ventilation openings could be impeded.
- Always set the VOLUME control to minimum before starting the audio source: increase the volume gradually to an appropriate level after play has started.
- When not planning to use this unit for long periods of time (ie., vacation, etc.), disconnect the AC power plug from the wall outlet.
- Grounding or polarization – Precautions should be taken so that the grounding or polarization of an appliance is not defeated.
- Do not use force on switches, controls or connection wires. When moving the unit, first disconnect the power plug and the wires connected to other equipment. Never pull the wire itself.
- Do not attempt to clean the unit with chemical solvents; this might damage the finish. Use a clean, dry cloth.
- Be sure to read the “TROUBLESHOOTING” section regarding common operating errors before concluding that the unit is faulty.
- To prevent lightning damage, disconnect the AC power plug and the antenna cable when there is an electrical storm.
- Do not plug the AC power plug to the wall socket before you finish all connections.
- Never allow metallic items (e.g. screwdrivers, tools, etc.) to come near the cassette deck's record/playback head assembly in this unit. Doing so may not only scratch or damage the head's mirror-smooth finish, it may change the magnetic characteristics of the heads, causing a deterioration in reproduction performance quality.
- Although the cassette deck's record/playback heads used in this unit are high quality heads with outstanding reproduction characteristics, they can become dirty through the use of old tapes or from dust accumulation over time. This can have a serious effect on reproduction quality. Clean the heads regularly with one of the commonly available head cleaners or with cleaning solutions.
- The voltage to be used must be the same as that specified on this unit. Using this product with a higher voltage than that which is specified is dangerous and may result in a fire or other type of accident causing damage. YAMAHA will not be held responsible for any damage resulting from use of this unit with a voltage other than that which is specified.
- The sound level at a given volume setting depends on speaker location and other factors. Care should be taken to avoid exposure to sudden high levels of sound, which may occur when turning on the unit with the volume control setting at high, and to continuous high levels of sound.
- Sudden temperature changes and storage or operation in an extremely humid environment may cause condensation inside the cabinet. Condensation can cause the unit to malfunction. To eliminate condensation:
  - **CD pickup**  
Leave the power on with no disc in the unit until normal playback is possible (about 1 hour).
  - **Tape head**  
Leave the power on with no cassette in the unit until normal playback is possible (about 1 hour).  
**Note**  
If condensation forms on the tape head, foreign matter may accumulate during use.
  - **Remote control**  
Wipe off condensation on the transmitter window with a soft cloth before operating the unit.

### IMPORTANT

Please record the serial number of this unit in the space below.

Serial No.:

The serial number is located on the rear of the unit.  
Retain this Owner's Manual in a safe place for future reference.

### WARNING

TO REDUCE THE RISK OF FIRE OR ELECTRIC SHOCK, DO NOT EXPOSE THIS APPLIANCE TO RAIN OR MOISTURE.

## PRECAUTIONS: READ THIS BEFORE OPERATING YOUR UNIT

### NOTE

Please check the copyright laws in your country to record from records, compact discs, radio, etc. Recording of copyright material may infringe copyright laws.

### CAUTION FOR CARRYING THIS UNIT

Be sure not to carry or tip this unit with discs remaining in it.

### CAUTION FOR MOVING THIS UNIT

Before moving this unit, first remove all discs from the disc table and close the table by pressing the OPEN/CLOSE button, and then switch off the power by pressing the POWER switch, and last, after you confirm that "no disc" is illuminated on the display, disconnect the power plug from the AC outlet.

The apparatus is not disconnected from the AC power source as long as it is connected to the wall outlet, even if the apparatus itself is turned off.

## WARNING

### DANGER

Invisible laser radiation when open and interlock failed or defeated.  
Avoid direct exposure to beam.

### CAUTION

Use of controls or adjustments or performance of procedures other than those specified herein may result in hazardous radiation exposure.

As the laser beam used in this unit is harmful to the eyes, do not attempt to disassemble the cabinet. Refer servicing to qualified personnel only.

To avoid electrical shock, do not open the cabinet. Refer servicing to qualified personnel only.

**DANGER:** The use of optical instrument with this product will increase eye hazard.

## PLACING THE SYSTEM

### Placing examples

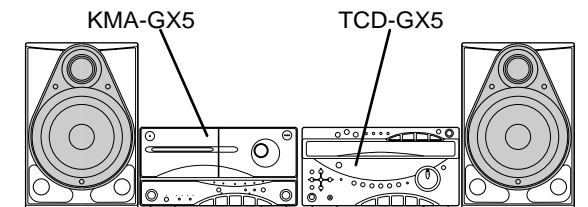
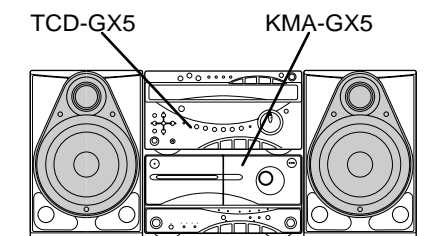

This system can be placed any way you like. If, however, you will place another unit or any object on top of KMA-GX5, be sure and prevent the ventilation holes on the top panel of it from being obstructed. If doing so, it may be damaged.

### Notes

- If the system is put in a rack, allow a space of at least 5 cm (1-15/16") above and behind the system.
- Disconnect the AC supply lead from the AC outlet before connecting or disconnecting any component.

## NAMES OF CONTROLS AND INDICATORS

(See figure 1 on page 5 at the beginning part of this manual.)

### TCD-GX5 (CD player/pre-amplifier/tuner)

- 1 Disc Table
- 2 Disc Selector Buttons
- 3 **RANDOM** Button
- 4 **REPEAT** Button
- 5 **TIME** Button
- 6 **EDIT** Button
- 7 Stop Button: □
- 8 Play/Pause Button: ▷/⏸
- 9 **PLAYXCHANGE** Button
- 10 **OPEN/CLOSE** Button: ▲
- 11 Skip Buttons: ◀◀/▶▶  
(Search Buttons: ◀◀/▶▶)
- 12 Remote Control Sensor
- 13 **LOCATION** Button
- 14 Equalizer Control Buttons
- 15 **USER** Button
- 16 **POWER** Switch
- 17 **MUSIC** Button
- 18 **PHONES** Jack
- 19 User Program **MEMORY** Button
- 20 Tuner **MEMORY (TIME ADJUST)** Button
- 21 **A/B/C/D/E (TIMER)** Button
- 22 **PRESET** ∨ (Down)/ ^ (Up) Buttons
- 23 **BAND** Button
- 24 **TUNING** ∨ (Down)/ ^ (Up) (**HOUR/MINUTE**) Buttons
- 25 **AUTO/MAN'L** Button
- 26 Input Selector Buttons
- 27 **MIC** (Microphone) Jack  
(Equipped on Australia, Singapore and General Models Only)
- 28 **MIC MIXING** (Microphone Mixing) Level Control  
(Equipped on Australia, Singapore and General Models Only)
- 29 **VOLUME** Control
- 30 **DISPLAY** Button

### Display

#### For CD player

- 1 **RANDOM** Play Indicator
- 2 Tape Side Indicator
- 3 **EDIT** Indicator
- 4 Program (**PGM**) Play Indicator
- 5 Play Indicator: ▷
- 6 Disc Indicator
- 7 Music Calendar Indicator
- 8 Music Calendar **OVER 15** Indicator
- 9 Track Number Indicator
- 10 (**S, F**) **REPEAT** Indicator
- 11 Time Display

#### For pre-amplifier/tuner

- 12 Preset Equalizer Mode Indicator (**MUSIC**)
- 13 Sound Field Mode Indicator (**LOCATION**)
- 14 User Program Number Indicator
- 15 **SLEEP** Indicator
- 16 **TIMER** Set Indicator
- 17 **AUTO** Tuning Indicator
- 18 **MEMORY** Indicator
- 19 **STEREO** Indicator
- 20 **TUNED** Indicator
- 21 Graphic Equalizer Level Indicators
- 22 Preset Number Indicator
- 23 Band Indicator
- 24 Station Frequency Display

\* Parts in shaded areas (■) on the figure 1 are equipped on Australia, Singapore and General models only.

## NAMES OF CONTROLS AND INDICATORS

(See figure 2 and 3 on page 6 at the beginning part of this manual.)

### KMA-GX5 (Tape deck/power amplifier)

- 31 DECK A Cassette Compartment
- 32 DECK A/B Button
- 33 DECK A Indicator
- 34 DECK B Indicator
- 35 PLAY Indicator
- 36 DUBBING (NORMAL/HIGH) Buttons and Indicators
- 37 REC/PAUSE Button and Indicator
- 38 DECK B Cassette Compartment
- 39 DECK A EJECT Button
- 40 TIMER REC Button and Indicator
- 41 Reverse MODE Selector Button and Indicators
- 42 DOLBY NR Button and Indicators

- 43 Fast Wind Button: <<
- 44 Play Direction Indicator
- 45 Play Button: <
- 46 Stop Button: □
- 47 Play Button: >
- 48 Play Direction Indicator
- 49 Fast Wind Button: >>
- 50 DECK B EJECT Button

### NX-GX5 (Speakers)

- 51 YST Port
- 52 Speaker Terminals

## REMOTE CONTROL TRANSMITTER

### Names of control buttons

(See figure 4 on page 7 at the beginning part of this manual.)

#### ■ Pre-amplifier/tuner control buttons

- 1 Remote Control Transmitter Window
- 2 Preset Station Number Buttons
- 3 A, B, C, D, E Selector Buttons
- 4 LOCATION Button
- 5 Equalizer Control Buttons
- 6 USER Button
- 7 POWER Switch
- 8 SLEEP Button
- 9 INPUT Selector Button
- 10 VOLUME – (Down)/+ (Up) Buttons
- 11 FLAT Button
- 12 MUSIC Button
- 13 TUNER Input Selector Button

#### ■ CD player control buttons

- 14 Track Number Input Buttons
- 15 TIME Button

- 16 DISC SKIP Button
- 17 Skip Buttons: <</>>  
(Search Buttons: <</>> )
- 18 Disc Play MODE Selector Button
- 19 REPEAT Button
- 20 RANDOM Button
- 21 OPEN/CLOSE Button: ^
- 22 PLAY/PAUSE Button: > ▢
- 23 STOP Button: □
- 24 EDIT Button
- 25 TAPE Button
- 26 PROGRAM Button

#### ■ Tape deck control buttons

- 27 Play Button: <
- 28 Stop Button: □
- 29 Play Button: >
- 30 Fast Wind Button: <<
- 31 Fast Wind Button: >>
- 32 DECK A/B Button
- 33 REC/PAUSE Button: ○ ▢

## REMOTE CONTROL TRANSMITTER

### Loading the batteries for the remote control transmitter

(See figure 5 on page 7.)

- 1 Remove the battery compartment cover.  
(Press the left edge of the cover to right with a finger, and then pull it upward.)
- 2 Insert 2 "AA" size batteries (UM/SUM-3, R6, HP-7 or equivalent) into the battery compartment.  
\* Installing the batteries improperly may cause failure.
- 3 Replace the battery compartment cover.

#### Precautions for battery use

- Insert the batteries according to the direction indicated in the battery compartment.
- Replace all batteries with new ones at the same time.
- Remove the batteries if they are weak or if the unit is not in use for long periods.
- Don't mix normal batteries with rechargeable batteries.

### Proper use of the remote control transmitter

(See figure 6 on page 7.)

Aim (within the range of 60° with no obstacles) the remote control transmitter at the remote control sensor and operate as shown.

#### Notes concerning use

- Replace the batteries if control distance decreases or operation becomes unstable.
- Periodically clean the transmitter window on the remote control transmitter and the sensor on the main unit with a soft cloth.
- Exposing the sensor on the main unit to strong light (especially an inverter type of fluorescent lamp etc.) may interfere with operation. In this case, reposition the main unit to avoid direct lighting.
- Keep the remote control transmitter away from moisture, excessive heat, shock and vibrations.
- The remote control transmitter's usable range is within 0.2m (8") and 6m (20') away from the sensor.

## REMOVING THE FRONT GRILLE

(See figure 7 on page 8.)

The front grille is fastened to the enclosure at three points, and can be removed if desired. To remove the grille, hold on to the frame and slowly pull straight away from the speaker. To reattach, line up the three pegs on the inside surface of the grille with the three corresponding holes on the speaker and push gently.

#### Note

When the grille is removed, take care not to touch the speaker units with your hands or to exert excessive force with tools.

## LISTENING WITH HEADPHONES

(See figure 8 on page 8.)

- Be sure that your headphones have a 3.5 mm (1/8") diameter plug and are between 16 ohms and 50 ohms impedance. Recommended impedance is 32 ohms.
- When headphones are connected, the speakers are defeated automatically. Adjust the VOLUME control for desired volume.

## CONNECTIONS

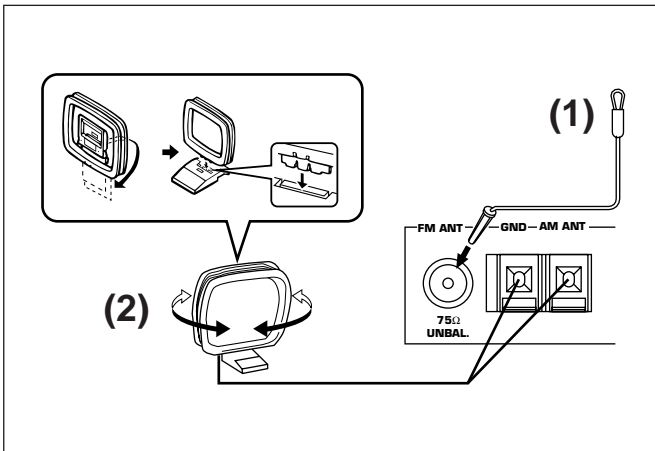

### Antenna connection

#### (1) Supplied FM antenna

Connect the FM antenna wire to the corresponding terminal and direct the FM antenna wire to the direction where the strongest signal can be received.

#### (2) Supplied AM (MW/LW) loop antenna

Connect the AM (MW/LW) loop antenna wires to the corresponding terminals. Position the AM (MW/LW) loop antenna for optimum reception. Place the AM (MW/LW) loop antenna on a shelf etc., or install it on the rack or wall with screws (not supplied).

#### Notes

- When static is still heard even after adjusting the position of the AM (MW/LW) loop antenna, try reversing the wire connections (top to bottom).
- Do not place the AM (MW/LW) loop antenna on the unit. It will result in noise generation, since the unit is equipped with digital electronics. Place the AM (MW/LW) loop antenna away from the unit.

#### (3) External FM antenna

Use an external FM antenna instead of an indoor FM antenna if you need better reception. Consult your dealer.

#### (4) External AM (MW/LW) antenna

Use an external AM (MW/LW) antenna if you need better reception. Consult your dealer.

#### Note

When using an external AM (MW/LW) antenna, be sure to keep the wire of the AM (MW/LW) loop antenna connected.

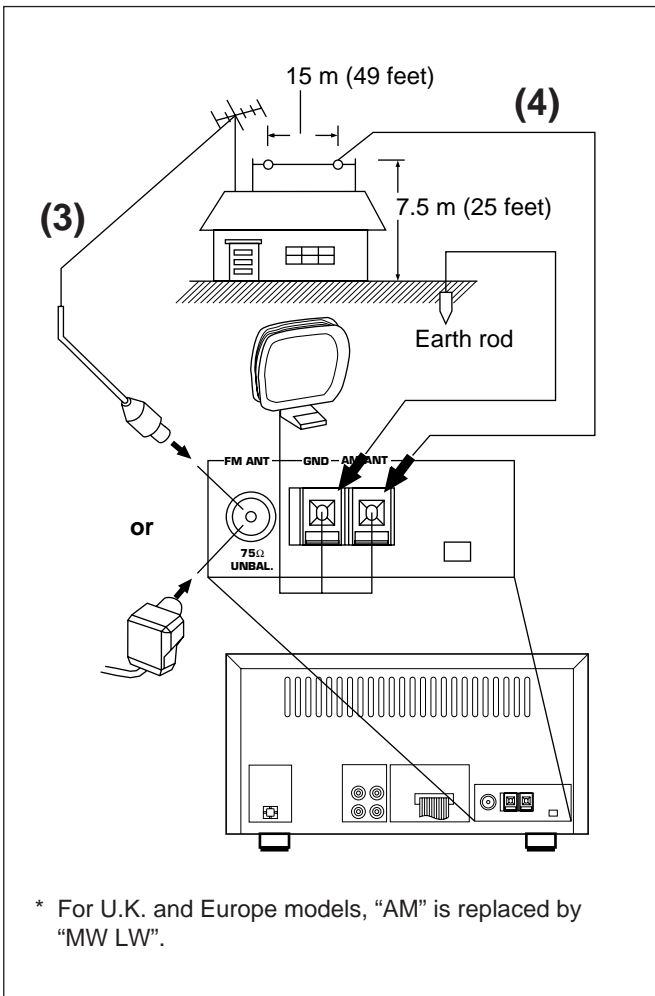

#### FREQUENCY STEP switch (Singapore and General models only)

Because the interstation frequency spacing differs in different areas, set the FREQUENCY STEP switch (located at the rear) according to the frequency spacing in your area. Before setting this switch, disconnect the AC supply lead of this unit from the AC outlet.



## CONNECTIONS

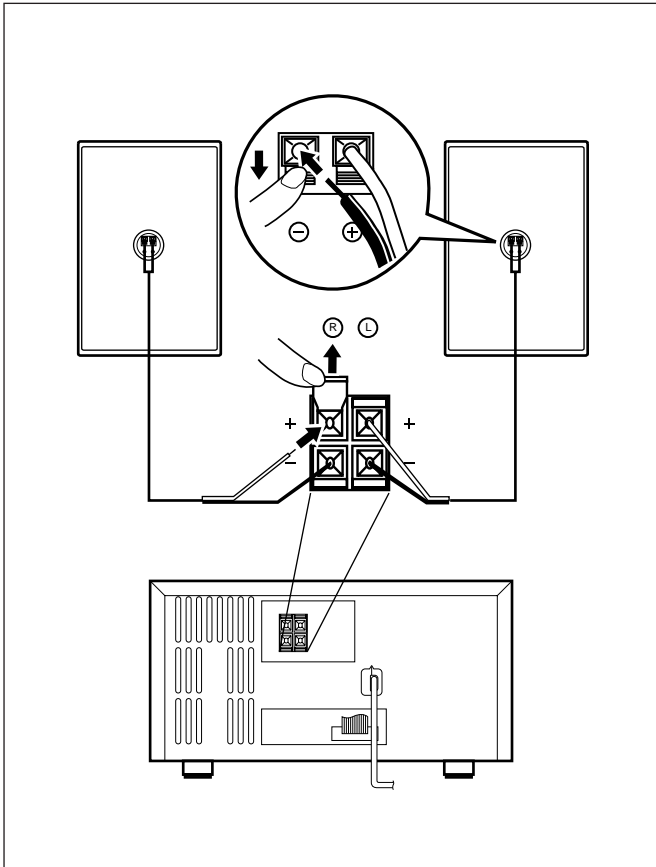

### Speaker connection

Connect each speaker wire to the SPEAKERS terminals.

#### Cautions

- Do not let the bare speaker wires touch each other as this could damage the power amplifier and/or speakers.
- When connecting the speakers to the unit, be sure to connect the speaker wires properly. Do not make a mistake from the right channel to the left channel and from the plus (+) terminal to the minus (-) terminal.
- Do not connect these SPEAKERS terminals to speakers other than the provided speaker system NX-GX5.

### System connection

(See figure 9 on page 8.)

Connect the red connector on the rear of TCD-GX5 to the red socket on the rear of KMA-GX5.

#### How to disconnect the system connector

Grasp both sides of the connector to disconnect the connector.

### Connecting the AC supply lead

(See figure 10 on page 8.)

- After connecting the speakers and system connectors, plug the AC supply lead into a convenient AC outlet.
- Unplug the AC supply lead from the AC outlet if the unit is not to be used for a long period of time.

## TURNING THE POWER ON/OFF TO THIS SYSTEM

(See figure 11 on page 8.)

If the AC supply lead is connected to the AC outlet, this system can be turned ON and OFF (STANDBY mode) by pressing the POWER switch on the front panel of TCD-GX5 or the POWER switch on the remote control transmitter.

#### Automatic power-off function

The power of this system will be automatically turned off if there is no operation on the control parts of this system, no illumination on the graphic equalizer indicators and no playback of CD or tape for about 30 minutes.

#### STANDBY mode

While the power is on, pressing the POWER switch (or the POWER switch on the remote control transmitter) switches the system to the STANDBY mode. (In this mode, the display shows only the time.) In this mode, main voltage is still present inside the system. If you want to switch off the system completely, disconnect the AC power plug from the AC outlet.



## SETTING THE CLOCK

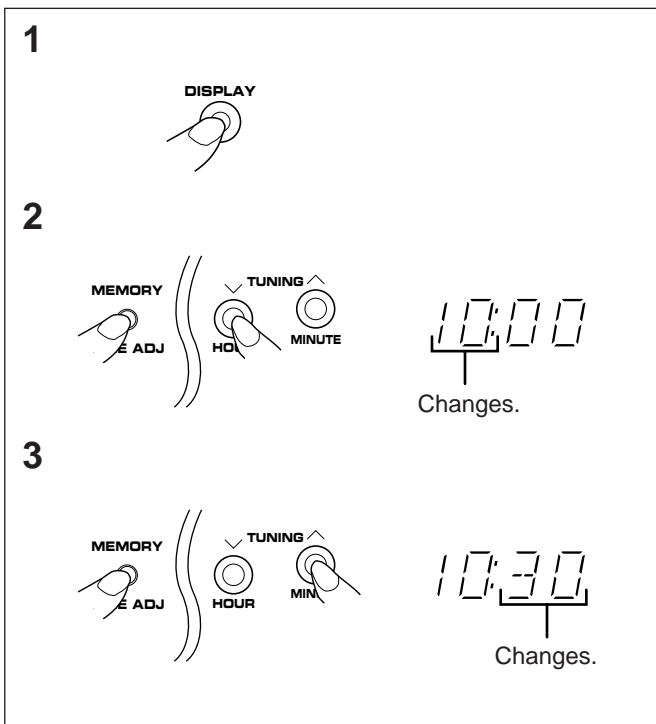

- 1** While the power is on, press the DISPLAY button to display the time. If the power is off, you can proceed to the next step.
- 2** While pressing the TIME ADJ button, press the HOUR button and set the hour.
  - \* Press the HOUR button once to advance the time by 1 hour. Press and hold to advance continuously.
- 3** While pressing the TIME ADJ button, press the MINUTE button and set the minute.
  - \* Press the MINUTE button once to advance the time by 1 minute. Press and hold to advance continuously.
  - \* The hour setting will not advance even if minute is advanced from "59" to "00".

### In the event of a power failure or when the AC supply lead is disconnected.

The time display will go out, however, the clock will function for about 5 minutes without power supply. So you do not have to reset the time if the AC power supply is resumed within about 5 minutes.

When the AC power supply is resumed after more than 5 minutes pass without power supply, the time display will flash on and off to indicate that the time must be reset.

### Note

If this system is left for several minutes without setting the time after the AC power lead of this system is connected to the AC outlet, there may be a case that the display is turned into a demonstration mode. (This mode is virtually unnecessary for using this system.)

In this case, first turn the power on by pressing the POWER switch to cancel the mode, and then set the time.

## VOLUME CONTROL

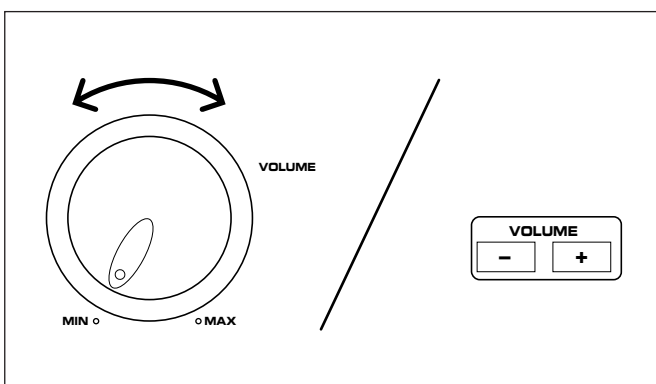

### Front panel operation

Rotate the VOLUME control towards MAX to increase the volume, and towards MIN to decrease the volume.

### Remote control operation

Press the VOLUME + button to increase the volume and the VOLUME - button to decrease the volume.



# COMPACT DISC PLAYER OPERATION

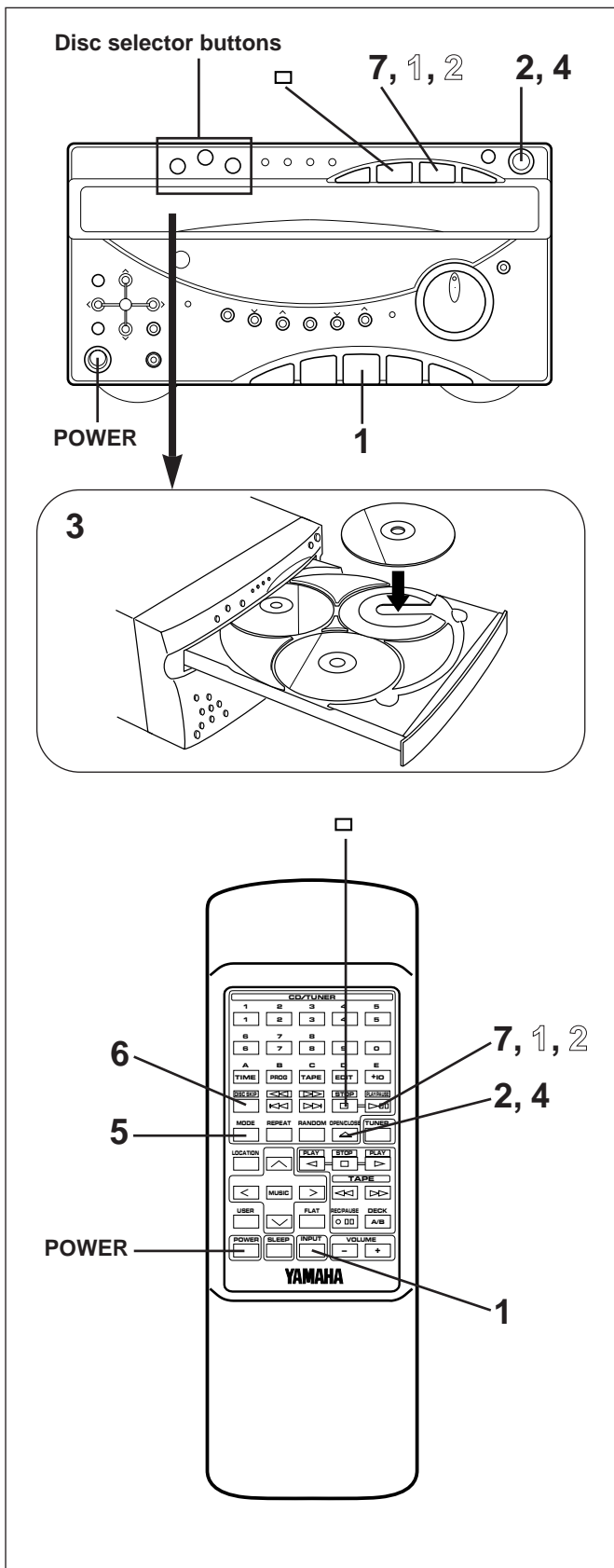

## CD playback

- 1 Press the CD input selector button.
- 2 Press the OPEN/CLOSE button to open the disc table.
- 3 Place discs on the trays, label side up.
  - \* Up to three discs can be loaded on the trays.
  - \* 8 cm (3") discs may be played without an adaptor.
- 4 Press the OPEN/CLOSE button to close the disc table.
  - \* The total number of tracks and the total playing time of the disc being selected will be displayed for several seconds.
  - \* The music calendar will be displayed only for the number of tracks on the disc being selected.
  - \* If the compact disc contains more than 15 tracks, the "OVER 15" indicator will light up on the music calendar.

The disc on the tray located on top of this indicator is now being selected.

Music calendar

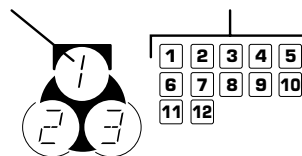

Total number of tracks

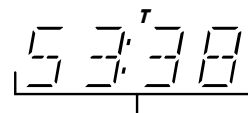

Total playing time

- 5 If necessary, change the disc play mode by pressing the disc play MODE selector button on the remote control transmitter while watching the display.

**Single disc play mode:** Only a designated disc is played back.

**All disc play mode:** All discs on the disc table are played back sequentially.

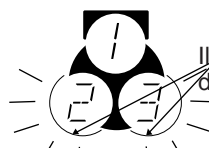

Illuminates only when the all disc play mode is selected.

- 6 If necessary, select another disc by pressing the DISC SKIP button on the remote control transmitter once or more (so that the corresponding disc tray number is located on top of the disc indicator).
- 7 Press the play/pause button to start playback from track 1.
  - \* The "▶" indicator will appear and playback will begin. As the playback of each track on the music calendar is finished, that track number will go out.

### For easier operation

Pressing the disc selector button (1, 2 or 3) will select the disc directly, and playback will begin from track 1 automatically.



# COMPACT DISC PLAYER OPERATION

## To interrupt playback

- 1 Press the play/pause button.  
\* The "▶" indicator will flash.
- 2 Press the play/pause button to resume playback from the same point.

## To stop playback

Press the stop □ button.

## To switch the unit off after use

Turn the unit off by pressing the POWER switch. (The indicators will go off except for the current time display.)

## Direct operation

Even when an input source other than CD player is selected, pressing the play/pause button, a disc selector button, a track number input button or the RANDOM play button, or pressing the front edge of the disc table gently will start playback directly. In this case, if the tape deck is playing back a tape, it will be stopped automatically.

\* These ways of playback can also be used to close the disc table. If the table is closed in these ways, playback will begin automatically, however, the display will not show the total number of tracks and the total playing time of the disc to be played.

## PLAYXCHANGE

During playback, you can open the disc table by pressing the PLAYXCHANGE button without interrupting disc playback. However, in this case, pressing the DISC SKIP button on the remote control transmitter has no effect.

## Precautions

- If TV or radio interference occurs during CD player operation, move the unit away from the TV or radio.
- Subjecting the unit to shock or vibration can cause mistracking.
- Playing some compact discs at high volume can cause mistracking. In this case, listen at lower volume.
- Do not pull open the disc table forcibly with your hands.
- Do not push the disc table while it is moving.
- If the power fails while the table is open, wait until the power supply returns or gently push the table manually to close it.
- The temperature range for playing compact discs is recommended to be 5°C (41°F) – 35°C (95°F).

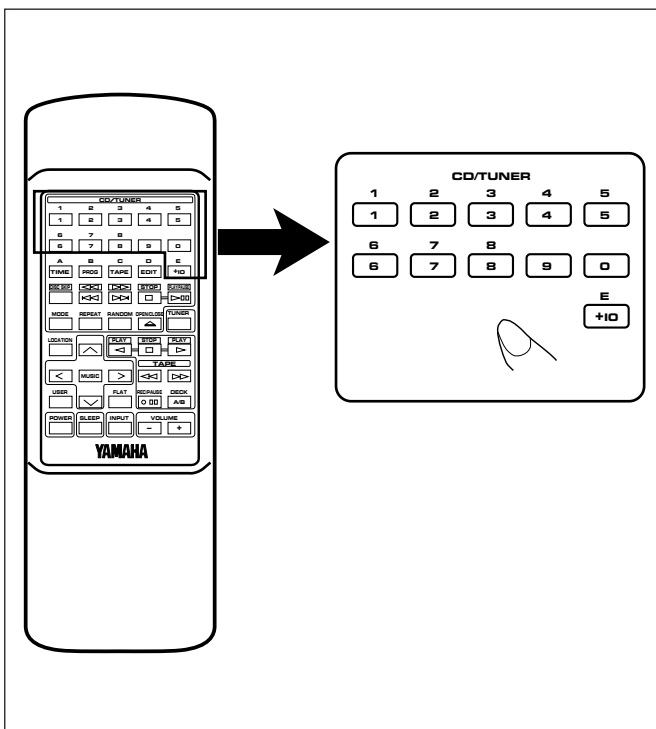

## Direct-selection play

By using the track number input buttons on the remote control transmitter, any track you wish to listen to can be played directly.

Use the track number input buttons to select the desired track number. Play will begin automatically.

### A. For example, to choose selection 5

Press the "5" button.

### B. For example, to choose selection 12

- (1) Press the "+10" button.
- (2) Within 3 seconds, press "2" button.

### C. For example, to choose selection 20

- (1) Press the "+10" button.
- (2) Within 3 seconds, press the "+10" button again.
- (3) Within 3 seconds, press the "0" button.

## Note

A track number higher than the number of tracks on the disc cannot be selected. Also, if a higher track number is selected while the disc table is open, play will begin from the last track on the disc when the disc table is closed.



## COMPACT DISC PLAYER OPERATION

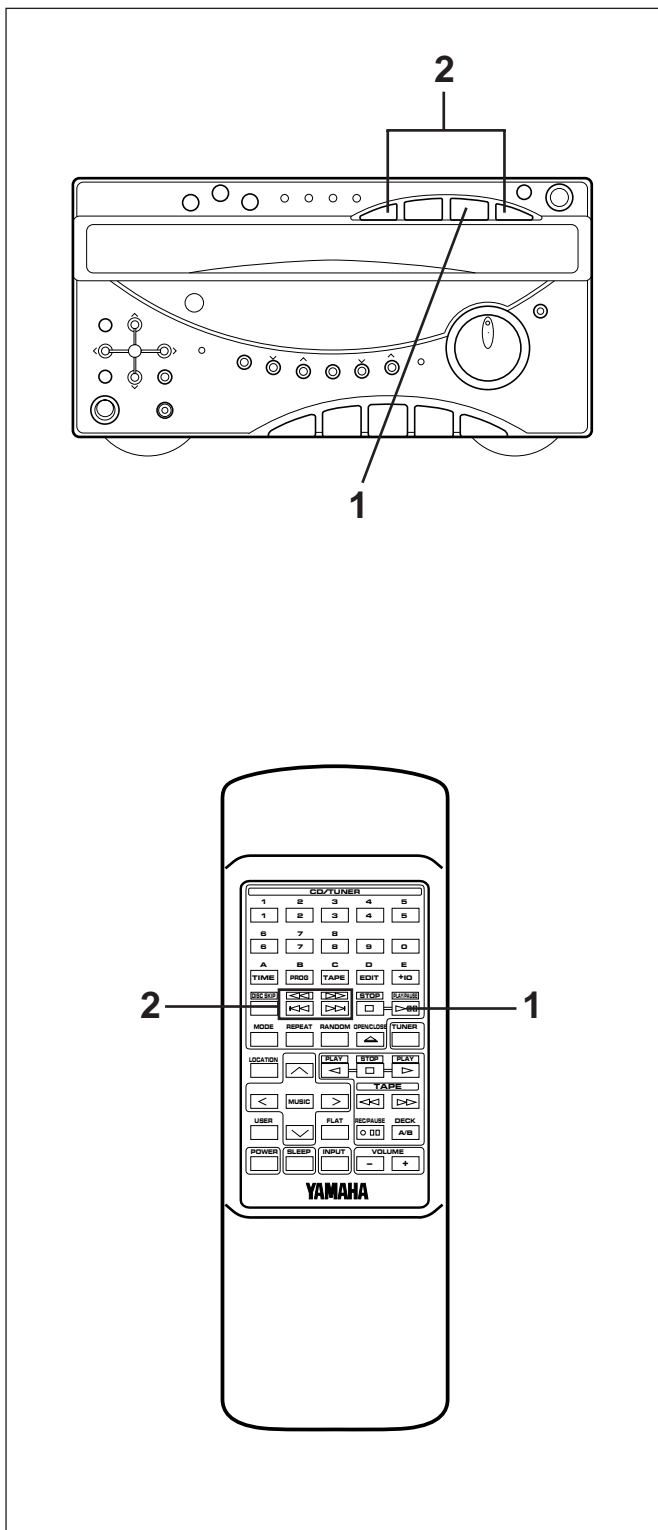

“Skip search” and “Manual search” are performed using the same buttons.

### Skip search

The beginning of any track can be found automatically.

- 1 Select a disc and begin playback.
- 2 Press the  $\triangleright\triangleright$  button to advance or  $\triangleleft\triangleleft$  button to reverse through the disc.  
Press once for each track to be advanced or reversed.
  - Press  $\triangleright\triangleright$  once to advance to the track following the one now playing back.
  - Press  $\triangleleft\triangleleft$  once to return to the start of the track now playing back.
  - Press  $\triangleleft\triangleleft$  twice to return to the track before the track now playing back.

#### Notes

- This function can also be performed while the unit is stopped. Press the play/pause button when your desired track number appears in the track number display. Playback will begin from the beginning of the track.
- This function will be performed forward or backward from any point on the disc. However, it will not move forward during playback of the final track.

### Manual search

- 1 Begin playback.
- 2 Press and hold the  $\triangleright\triangleright$  button to advance play rapidly, and the  $\triangleleft\triangleleft$  button to reverse play rapidly.
  - \* The sound can be heard (although slightly garbled) during manual search in either direction. This is convenient for reviewing the contents quickly.

#### Note

Manual search can also be performed while playback is paused, though no sound will be heard.



# COMPACT DISC PLAYER OPERATION

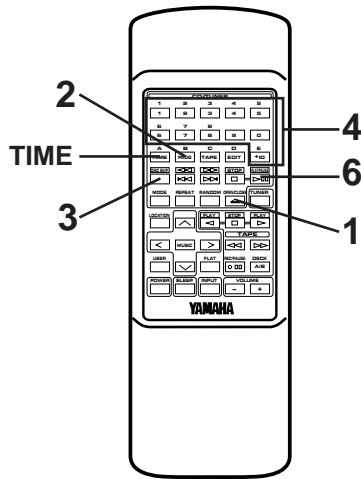
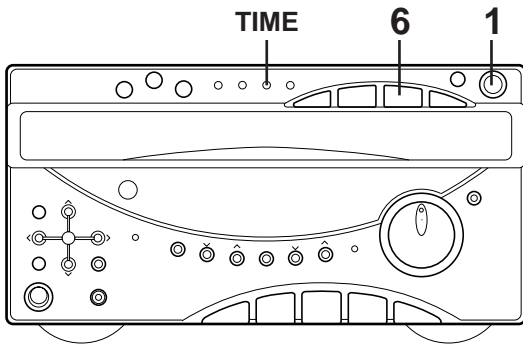

## Display information during programming

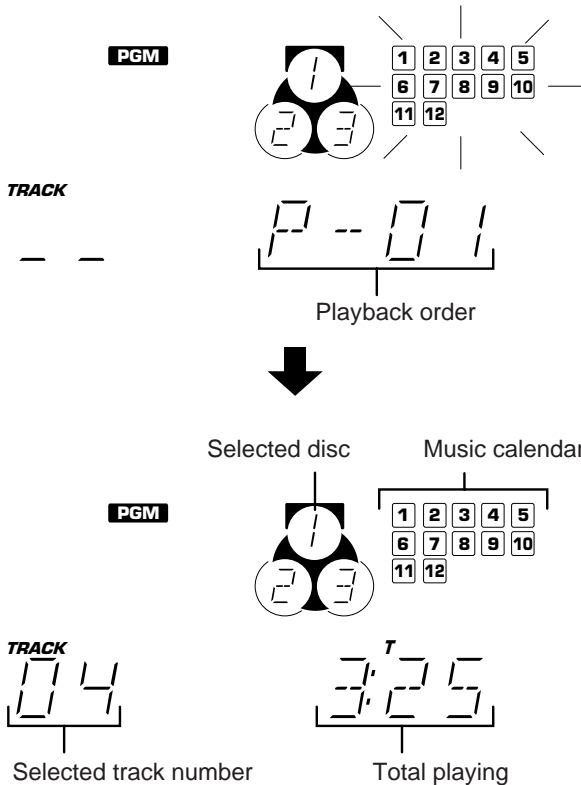

## Program play

You can program up to 20 tracks in any desired order.

- 1** Load discs and close the disc table.
- 2** When in the stop mode, press the PROG button to prepare for programming.
  - \* "PGM" and "P-01" will light up on the display, and all track numbers on the selected disc begin flashing.
- 3** If necessary, select a desired disc by pressing the DISC SKIP button.
- 4** Use the track number input buttons to select the desired track number.
  - \* The selected track number and the total play time of the programmed tracks will light up on the display, and soon it is replaced by the display of the next playback order. Programmed track numbers on the selected disc will stop flashing and light up on the music calendar.
  - \* Pressing the TIME button displays the total play time of the programmed tracks for about 1 second, and then it is replaced by the display of the next playback order.
- \* **For example, to choose selection 12**
  - (1) Press the "+10" button.
  - (2) Within 3 seconds, press the "2" button.
- 5** Repeat steps 3 and 4 for any other track. Up to 20 tracks can be programmed.
- 6** Press the play/pause button to start playback of programmed tracks.

## Notes

- It is also possible to program a sequence of tracks while looking at the list of tracks on the surface of the disc before closing the disc table.
- During playback or pause, programming is not possible.
- If the total time of the programmed tracks reaches 100 minutes or more, only the last two-digits will be displayed for the three-digit number.
- The total time of the programmed tracks will not be displayed, if a track number higher than 16 is programmed.
- Skip search can be performed during playing back, but only within the range of the programmed tracks.
- Manual search can be performed during playing back to search through all tracks, including unprogrammed tracks.
- If programs are made selecting tracks from more than one disc, pressing the PLAYXCHANGE button is useless during program play.



## COMPACT DISC PLAYER OPERATION

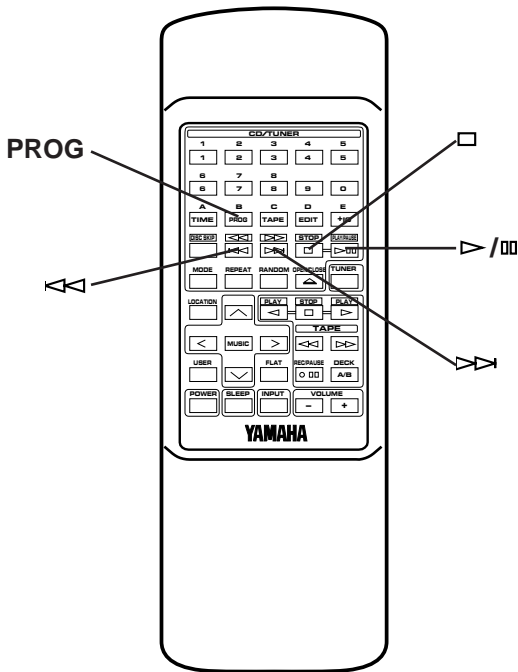
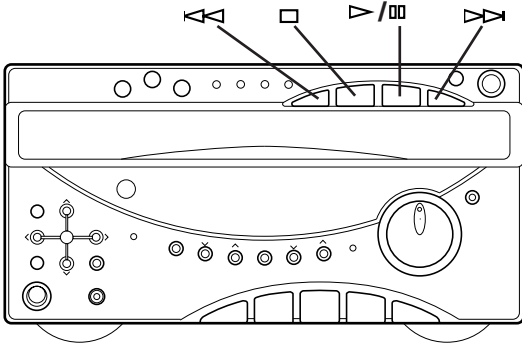

### To stop program play

- Press the stop  $\square$  button. The first programmed track number will be displayed.
- To resume playback, press the play/pause  $\triangleright/\parallel$  button. Playback will begin from the beginning of the program.

### To cancel a programmed sequence

There are several methods as described below.

- Press the stop  $\square$  button while the unit is stopped.
- Open the disc tray
- Switch off the power.

### To check program data

1. If during playing back, press the stop  $\square$  button.
2. Press the PROG button.
3. Each time the  $\triangleright\triangleright$  button is pressed, the track numbers and sequential order of the programmed tracks can be checked one after another. The display of the track number can be returned (sequentially in reverse order) by pressing the  $\triangleleft\triangleleft$  button.

### To correct program data

1. Follow the procedure described in "To check program data".
2. Display the track number to be corrected by pressing the  $\triangleright\triangleright$  or  $\triangleleft\triangleleft$  button.
3. Press a track number input button to select a track to replace the one displayed. The previously programmed track will be cleared from the memory and the new one will be programmed.
4. After the correction has been completed, press the PROG button or play/pause  $\triangleright/\parallel$  button once again.



# COMPACT DISC PLAYER OPERATION

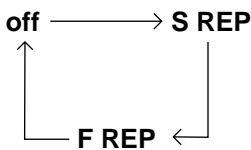
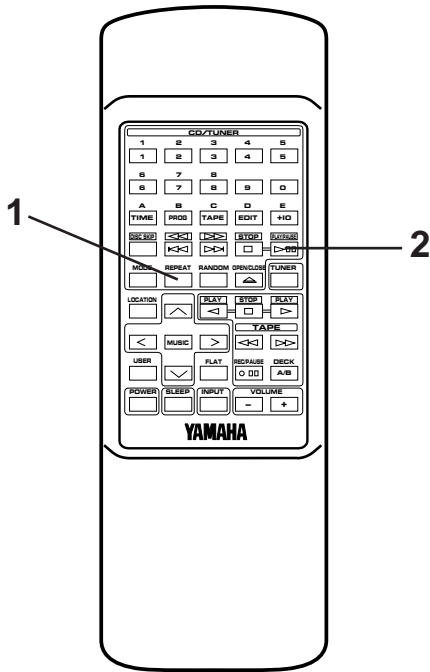
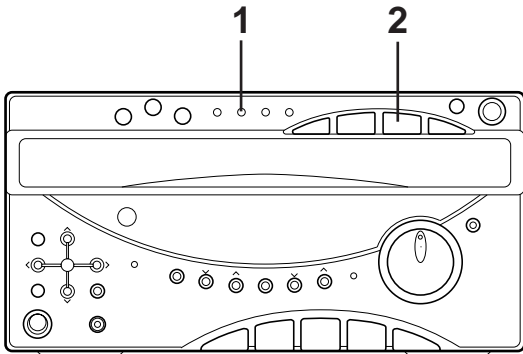

## Repeat play

All discs, an entire disc, a single track or a programmed sequence can be continuously repeated.

- 1 While watching the display, press the REPEAT button once or more to select a desired repeat play mode (S REP or F REP).
- 2 Press the play/pause button.

## Repeat play modes

### SINGLE REPEAT (S REP)

A single track is played back repeatedly.

\* This is also available in the program play mode and the random play mode. (If the repeat play mode is switched off, the program play mode or the random play mode will be resumed.)

### FULL REPEAT (F REP)

#### When the unit is in the single disc play mode:

A designated disc is played back repeatedly.

\* In the random play mode, the selected disc is repeatedly played back, but the order of tracks is different every time.

#### When the unit is in the all disc play mode:

All discs on the disc table are played back repeatedly.

\* In the random play mode, the random play is performed among all discs and repeated with a different order of tracks every time.

### Note

In the program play mode, a sequence of programmed tracks is played back repeatedly.

## To cancel the repeat play

Press the REPEAT button once or more so that the (S, F) REP indicator goes out.



## COMPACT DISC PLAYER OPERATION

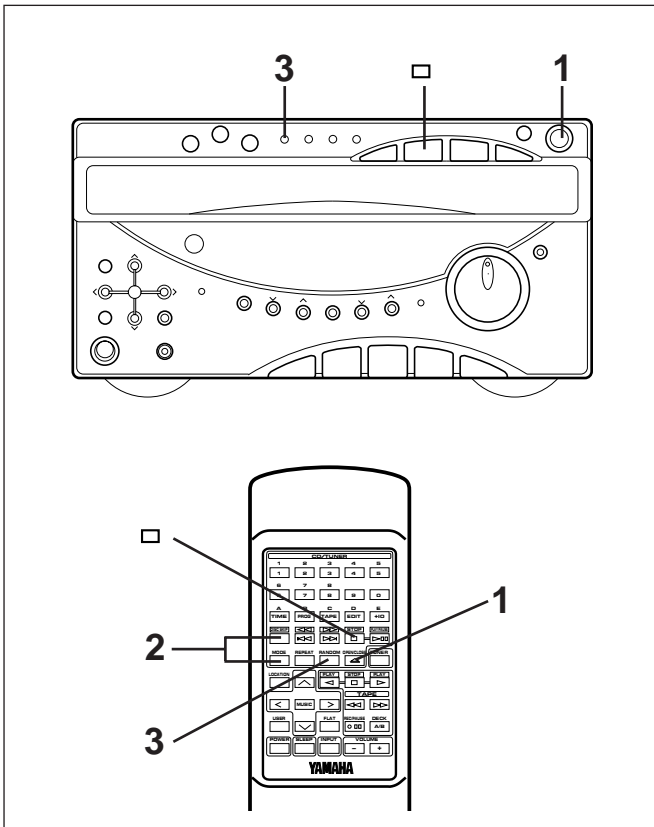

### Random play

Tracks on a selected disc or all discs on the disc table can be played back in a random order.

- 1 Load discs and close the disc table.
- 2 If necessary, switch the disc play mode by pressing the disc play MODE selector button.
  - \* If the single disc play mode is selected, select a desired disc by pressing the DISC SKIP button.
- 3 Press the RANDOM button to begin random play.
  - \* The "RANDOM" indicator will light up.

#### To cancel the random play

Press the stop  button, or press the RANDOM button again. The "RANDOM" indicator will go out.

#### Note

This feature will not function during programming, or during program play.

### Switching the time display

Each time the TIME button is pressed, the display will change as described below.

#### [Example]

When the second track is being played back (Refer to the illustration on the left.)

- ① The elapsed play time for the track now playing back will be displayed.
  - \* 8 seconds have passed since the beginning of the second track.
- ② The remaining play time for the current track will be displayed.
  - \* 2 minutes and 58 seconds remain till the end of the second track.
- ③ The total play time of the disc will be displayed. (If the unit is in the program play mode, the total play time of the programmed tracks will be displayed.)
- ④ The total remaining play time from the point being played at that time will be displayed.
  - \* 41 minutes remain till the end of the disc.

#### Notes

- During random play, the total remaining play time on the disc will not be displayed.
- During programming tracks or during program play, the total remaining play time will not be displayed for track number 16 or higher.

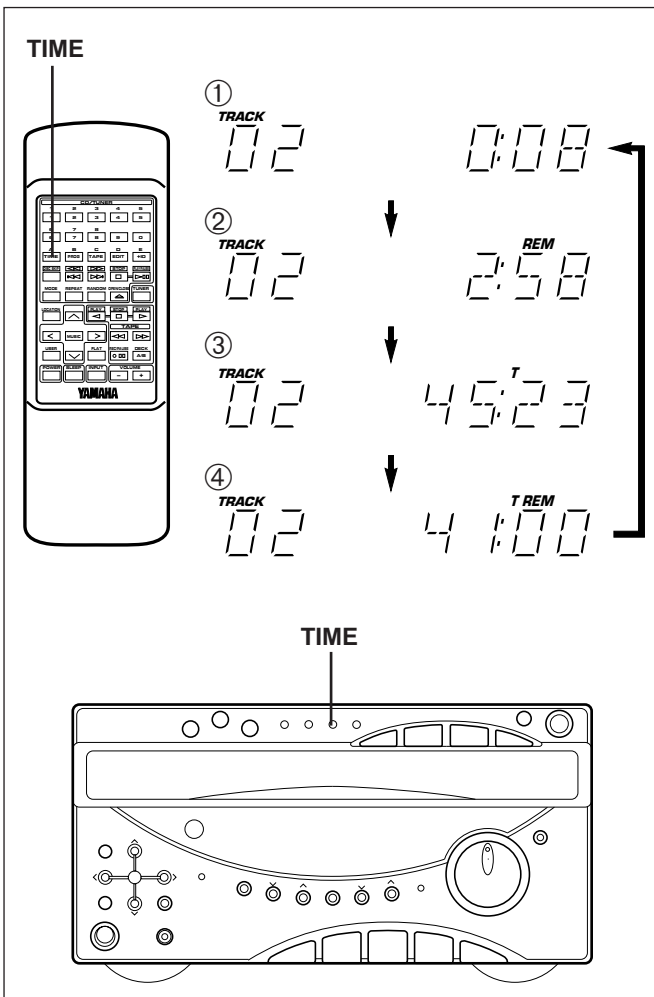





## TUNING OPERATION

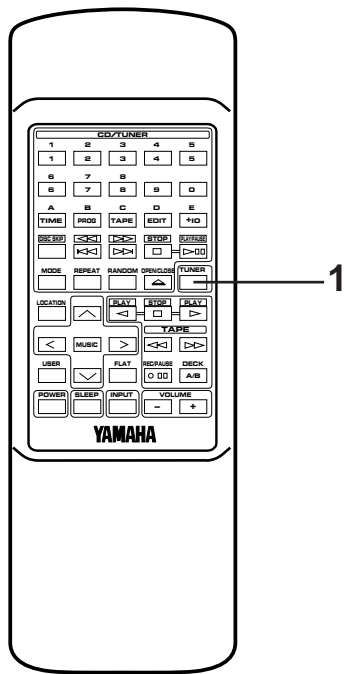
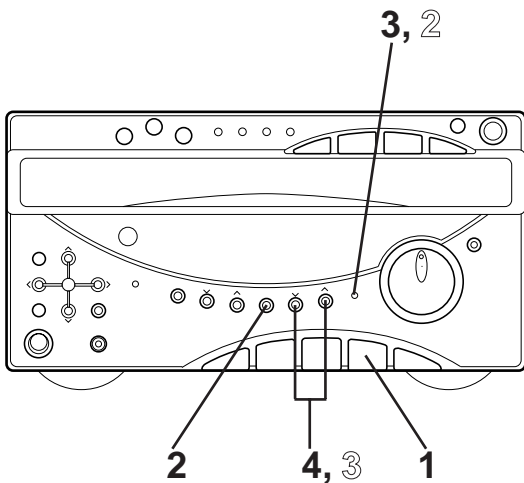

Normally, if station signals are strong and there is no interference, quick automatic-search tuning (Automatic tuning) is possible. However, if signals of the station you want to select are weak, you must tune to it manually (Manual tuning).

### Automatic tuning

- 1 Press the TUNER input selector button.
- 2 Select the reception band [FM or AM (MW or LW)] by pressing the BAND button while watching the display.
- 3 Press the AUTO/MAN'L button so that "AUTO" appears on the display.  
(In this mode, stations are received in stereo or monaural automatically.)
- 4 Press the TUNING ^ button to tune to a higher frequency, or press the TUNING v button to tune to a lower frequency.  
(When tuned to a station, "TUNED" will light up on the display.)
- 5 If the station where tuning search stopped is not the desired one, follow step 4 again.

- \* If the tuning search does not stop at the desired station, change to the Manual tuning method as described below.
- \* STEREO indicator will light up when an FM stereo broadcast with sufficient signal strength is received.

### Manual tuning

- 1 Follow steps 1 and 2 of the Automatic tuning method.
- 2 Press the AUTO/MAN'L button so that "AUTO" disappears from the display.  
(In this mode, stations are received in monaural.)
- 3 Press and hold the TUNING ^ button to tune to a higher frequency, or press and hold the TUNING v button to tune to a lower frequency.  
Release it just before reaching the desired frequency, and then press it repeatedly until the desired frequency appears.  
(When tuned to a station, "TUNED" will light up on the display.)

#### Note

If you tune to an FM station manually, it is received in monaural automatically to increase the signal quality.

"AM" is for U.S.A., Canada, Australia and General models.

"MW/LW" is for U.K. and Europe models.



## TUNING OPERATION

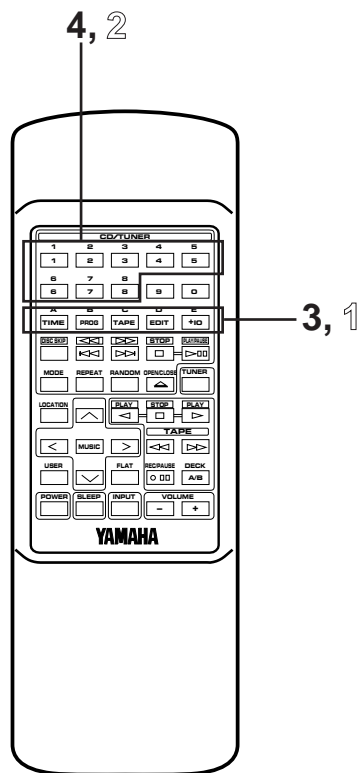
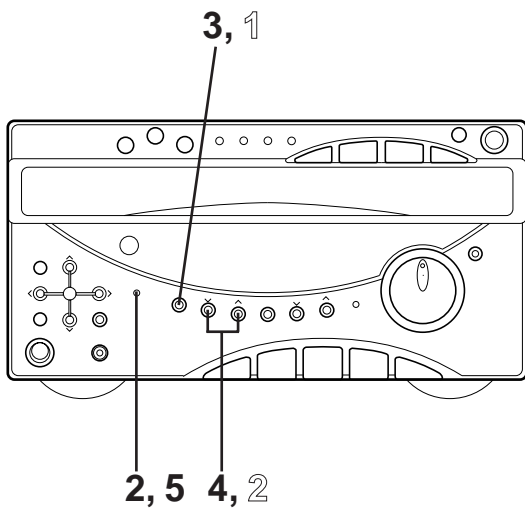

## Preset tuning

This unit can store up to 40 (8 stations x 5 areas) frequencies. With this function, you can select any desired station by only calling the corresponding preset station number.

### To store stations

(Example: To store a station to A1)

- 1 Tune to a desired station.  
(Refer to the previous page for tuning procedure.)
- 2 Press the tuner MEMORY button.  
\* The MEMORY indicator and "PRESET" will flash for about 5 seconds.
- 3 Select a desired area (A – E) by pressing the A/B/C/D/E button while watching the display, before the MEMORY indicator goes out.  
(In this case, select area A)
- 4 Select a preset station number by pressing the PRESET  $\vee$  or  $\wedge$  button repeatedly before the MEMORY indicator goes out.  
(In this case, select "1".)
- 5 Within about 5 seconds, press the tuner MEMORY button again.

AUTO STEREO  
TUNED

PRESET

A 1 FM 89.1 MHz

Shows the displayed station has been programmed to A1.

- \* In the same way, program other stations to A2, A3 ... A8.
- \* You can program more stations to the preset station numbers on other areas in the same way by selecting other areas in step 3.

### To recall a preset station

- 1 Select the area of preset station numbers by pressing the A/B/C/D/E button.
- 2 Select the desired preset station number by pressing the PRESET  $\vee$  or  $\wedge$  button repeatedly.

### Notes

- A new setting can be programmed in place of the former one.
- For presets the setting of the AUTO/MAN'L button is stored along with the station frequency.

### For easier operation

By using the preset station number buttons and the A,B,C,D,E selector buttons on the remote control transmitter, a preset station number and an area can be selected directly.



## TUNING OPERATION

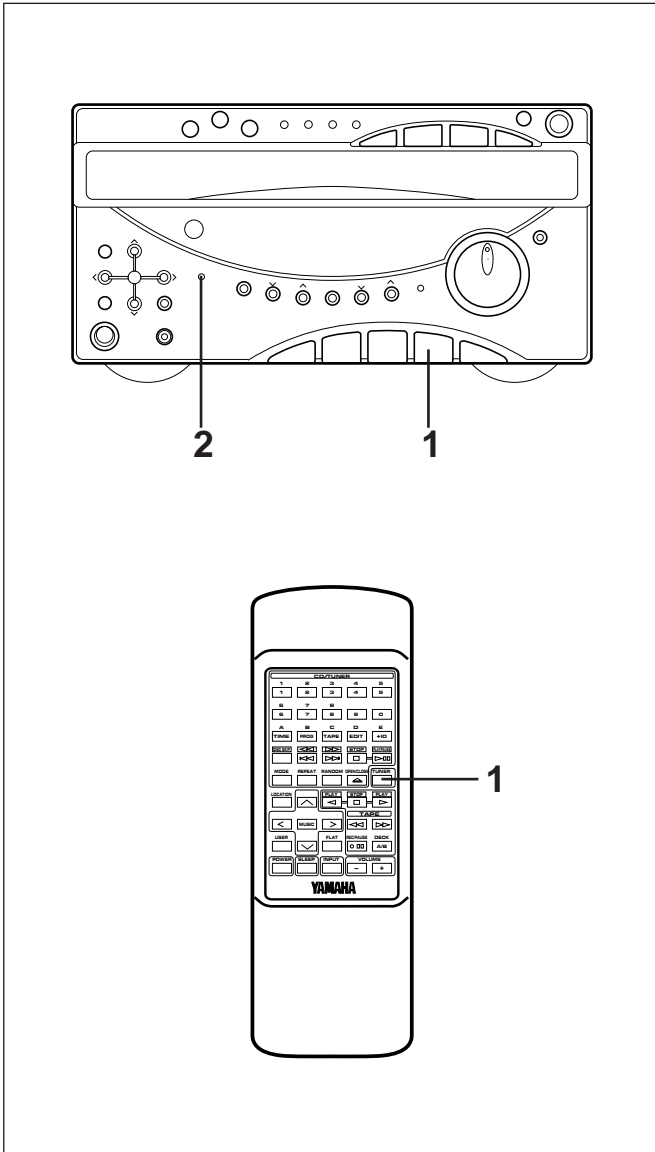

### Automatic preset tuning

You can also make use of an automatic preset tuning function. By this function, this unit performs automatic tuning and stores stations with strong signals sequentially. Up to 40 stations are stored automatically in the same way as in the manual preset tuning method on the previous page.

- 1 Press the TUNER input selector button.
- 2 Press and hold the tuner MEMORY button for about 2 seconds.
  - \* The MEMORY and AUTO indicators will flash.

This unit performs automatic tuning and received stations are programmed to A1, A2 ... A8 sequentially.

#### When the automatic preset tuning is completed

The display shows the frequencies of the first preset station (stored to A1).

Check the contents and the number of preset stations by following the procedure of the section "To recall a preset station" on the previous page.

#### To recall a preset station

Simply follow the procedure of the section "To recall a preset station" on the previous page.

#### Notes

- The automatic preset tuning search will be performed through all frequencies until 40 stations are stored. If the number of received stations is less than 40, the search will stop after searching through all frequencies.
- With this function, only stations with sufficient signal strength are stored automatically. If the station you want to program is weak in signal strength, tune to it in monaural manually and program it by following the procedure of the section "To store stations" on the previous page.
- You can replace a preset station by another FM or AM (MW or LW) station manually by simply following the procedure of the section "To store stations" on the previous page.

#### Fundamental rules of internal automatic preset tuning operation

Basically, FM stations are programmed onto area A, B and C, and AM stations are programmed onto area D and E (MW stations are onto D and LW stations are onto E) in that order automatically.

\* If, for example, the number of received FM stations is not enough to fill up three areas (A, B and C), AM (MW or LW) stations are programmed closely from the preceding empty areas. In such a case, AM (MW) stations are programmed from area B or C (and LW stations are from area C or D.)

\* Moreover, one area is programmed with stations of the same band only. If, for example, the last FM station is programmed to B4, B5–B8 will be programmed with no station, and AM (MW) stations are programmed from area C.

#### Memory back-up

The memory back-up circuit prevents the programmed data from being lost even if the AC supply lead is disconnected from the AC outlet or the power is cut due to temporary power failure. If, however, the power is cut for more than one week, the memory may be erased. If so, it can be re-programmed by simply following the Preset tuning steps.



## TAPE DECK OPERATION

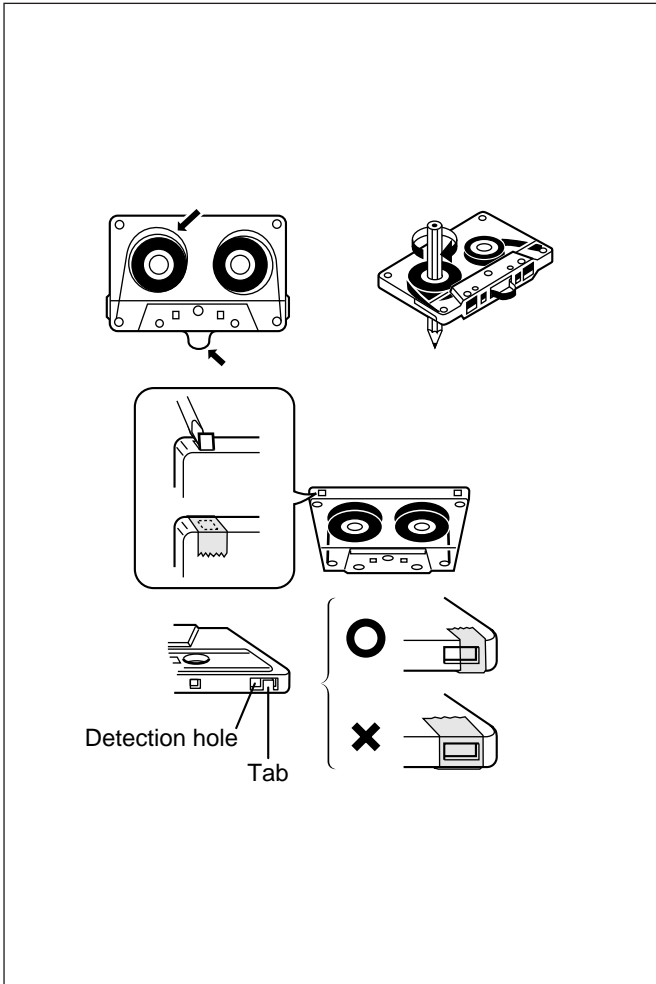

## General information

- Do not use C-120 tapes or poor-quality tapes, since they can cause malfunctions.
- Before loading a tape into the cassette compartment, tighten the tape slack with a pen or pencil.
- Tapes have removable tabs which prevent accidental recording or erasing from taking place. Removing the tab on the top left protects the side facing you from erasure. Cover the tab holes with adhesive tape to erase or record again.
- This deck is a Double Cassette Deck with Automatic Reverse Function.  
DECK A: Playback only.  
DECK B: Playback or recording.
- This deck features an auto tape selector. Just load the tape, and the tape formula being used will be sensed automatically.
- This unit can play back metal tapes as well as normal or chrome tapes, and recording can also be done on metal tapes.
- When covering erasure prevention tab holes, do not cover the chrome and metal detection holes. Otherwise, the deck will treat tape as normal tape.
- Do not press the EJECT button during playback or recording.



# TAPE DECK OPERATION

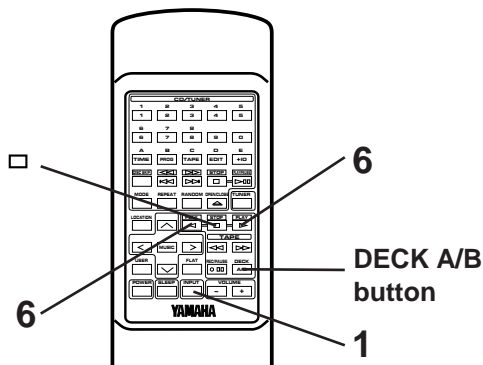
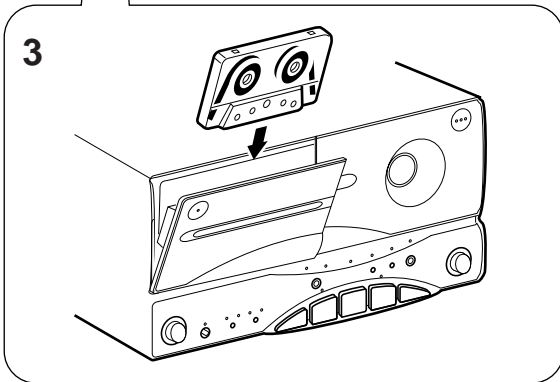
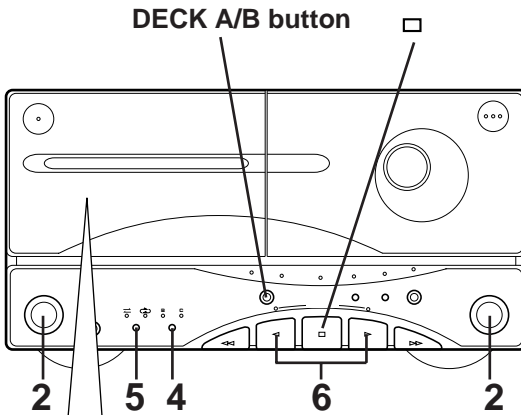
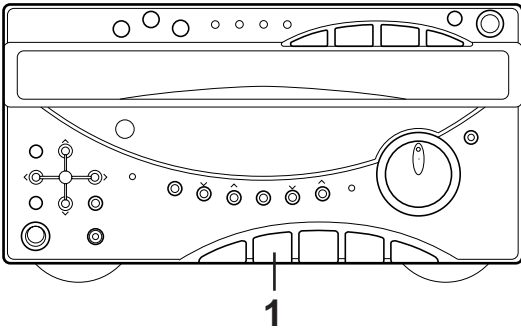

## Tape A or tape B playback

- 1 Press the TAPE input selector button.
- 2 Open the DECK A or DECK B cassette compartment by pressing the EJECT button.
- 3 Load the tape into the DECK A or DECK B cassette compartment, and close the lid panel completely by pressing the panel until it clicks.
  - \* If you have loaded two tapes into both the DECK A and B cassette compartments, select the DECK A or B in which the tape you want to play back is loaded by pressing the DECK A/B button so that the corresponding indicator lights up.
- 4 Select the Dolby NR B or C position by pressing the DOLBY NR button once or more so that the corresponding indicator lights up, if the tape has been recorded with Dolby noise reduction. If not so, set the DOLBY NR button so that neither of the indicators lights up.
  - \* For selection of the Dolby B or C position, refer to the "Dolby B and C Type Noise Reduction" on page 23.
- 5 If necessary, switch the reverse mode to the desired one by pressing the reverse MODE selector button so that the corresponding indicator lights up.

The reverse MODE selector button can be operated before or during playback, and changes tape playback as follows:

	Side A only	Side A → Side B ↑ (Repeats 8 times) Starts from side A.
	Side B only	Side A → Side B ↑ (Repeats 8 times) Starts from side B. (Side A is not played at the first time.)

- 6 Press the play button to listen to side A, or the play button for side B.

### To stop playback

Press the stop button.

### Note

When removing the tape, press the stop button, and then open the cassette compartment.

### Direct operation





Even if an input source other than tape deck is selected, pressing the play button (or the fast wind button) will start playback (or fast winding) directly.

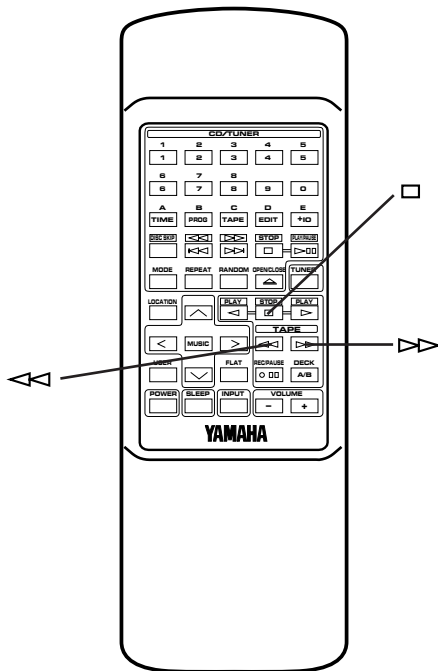
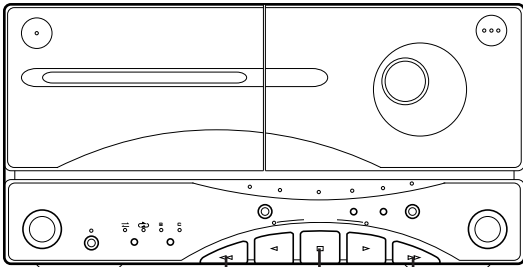

## TAPE DECK OPERATION



### Winding the tape

- 1 If during playback, first press the stop  button.
- 2 Next press the fast wind  or fast wind  button to wind the tape.
- 3 Press the stop  button to stop.

\* While winding the tape, the corresponding play direction indicator flashes rapidly.

#### Note

When the tape is wound to the end, this unit will then function as described below, according to the setting of the reverse mode.



 : The tape stops at the end.



 : When the tape reaches the end, playback automatically starts from the reverse side.

### Searching for the beginning of a desired selection



Carry out the following operation during playback to find the beginning of a desired selection on the tape.



#### To listen to the same selection

Press the  button if the direction of the current playback is .

Press the  button if the direction of the current playback is .

#### To listen to the next selection

Press the  button if the direction of the current playback is .

Press the  button if the direction of the current playback is .

\* While searching, the corresponding play direction indicator flashes slowly.

#### Notes

- This function may not work for tapes with
  - \* Material with long pauses or quiet passages.
  - \* Low recording levels or excessive noise.
  - \* Pauses of less than 4 seconds between selections.
- If searching is carried out at the first or the last part of a selection, the desired selection may not be found.



# TAPE DECK OPERATION

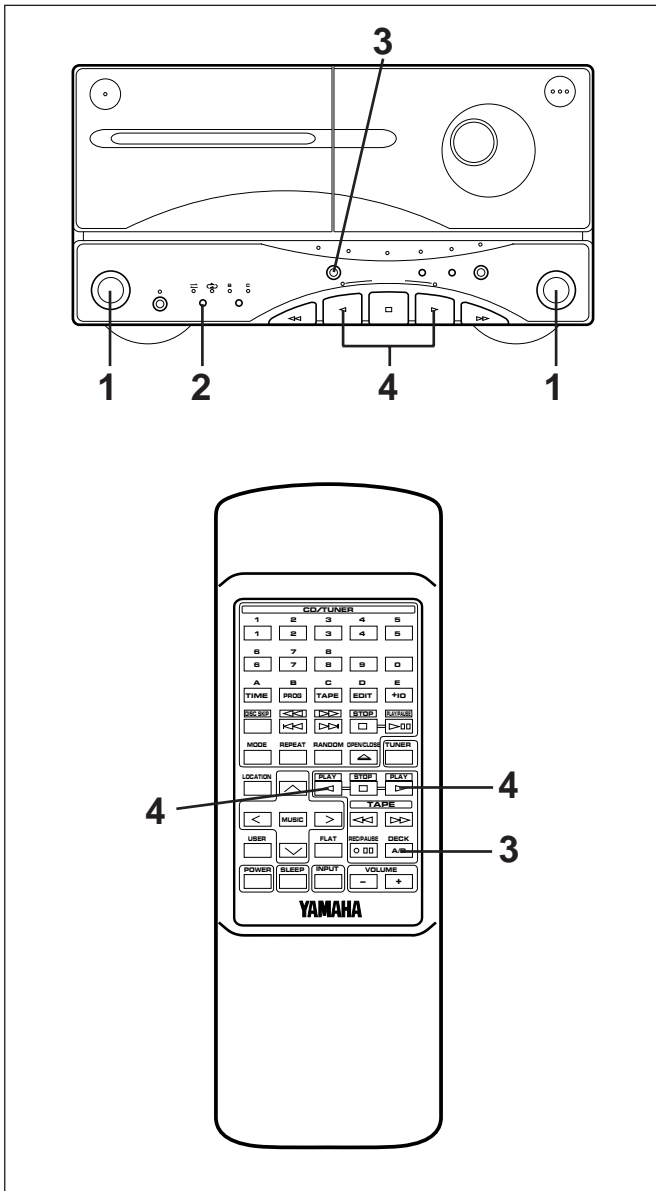

## Continuous playback

- 1 Load the tapes into the DECK A and DECK B cassette compartments.
- 2 If the reverse mode “↺” is not selected, press the reverse MODE selector button to select it.

The reverse MODE selector button can be operated before or during playback, and changes tape playback as follows:

<Tape A> 	Tape A Side A → B → Tape B Side A → B (Repeats 8 times) Starts from Tape A Side A.
<Tape A> 	Tape A Side A → B → Tape B Side A → B (Repeats 8 times) Starts from Tape A Side B. (Tape A Side A is not played at the first time.)

- 3 Select the tape to be played back first by pressing the DECK A/B button.
- 4 Press the play ▷ button to listen to side A, or the play ◁ button for side B.

## Dolby B and C Type Noise Reduction

With cassette tapes, the most noticeable form of noise is high frequency hiss. To reduce this hiss noise, this unit has been equipped with a newly developed Dolby C noise reduction system in addition to its conventional Dolby B NR. Either type of noise reduction may be selected with the switch provided. Dolby B NR has a noise reduction effect of about 10 dB in the high frequency range. The corresponding figure with Dolby C NR is about 20 dB, but this is over the entire range where the human ear is most sensitive to noise (2 kHz to 8 kHz). Also, Dolby C NR has the same noise reduction effect at both high and low signal levels. In addition, Dolby C NR improves the tape's MOL (Maximum Output Level). Dolby noise reduction is a 2 part process that acts both on recording and playback; be sure that the noise reduction button is set to the same position on record and play.

\* Noise in the source material cannot be reduced with the Dolby NR system.

Dolby noise reduction manufactured under license from Dolby Laboratories Licensing Corporation. "DOLBY" and the double-D symbol are trademarks of Dolby Laboratories Licensing Corporation.



## RECORDING COMPACT DISCS

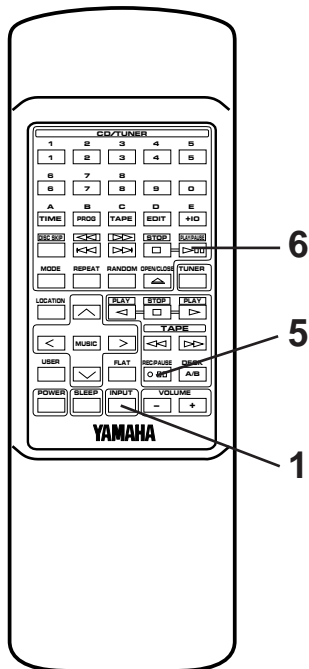
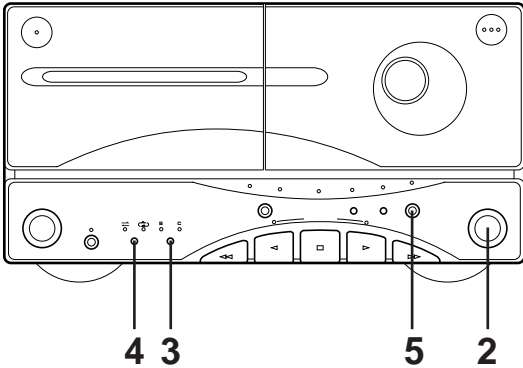
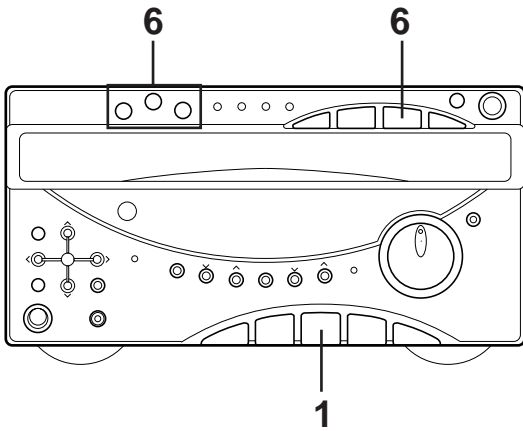

- When recording important selections, be sure to make a preliminary test to ensure that the desired source material is being properly recorded with good sound quality.
- The automatic recording level control circuit automatically controls the level of the input signal used for recording.
- Adjusting the VOLUME control and using the built-in sound field processor have no effect on the recorded sound.  
If, however, the built-in graphic equalizer is used, its effect is recorded along with the source.  
\* Music with an equalizer effect is suitable for listening to inside a car etc.
- For the tape deck, the deck which can be used for recording is the DECK B only. When recording, be sure to load a tape into the DECK B cassette compartment.

### CD synchronized recording

- 1 Press the CD input selector button and load the disc to be recorded.
- 2 Load a tape into the DECK B cassette compartment.  
\* Wind past the beginning part of the tape on which recording cannot be performed.
- 3 When recording with the Dolby NR system, select the Dolby NR B or C position by pressing the DOLBY NR button. If not, set it off.  
\* For selection of the Dolby B or C position, refer to the "Dolby B and C Type Noise Reduction" on page 23.
- 4 If desired, switch the reverse mode by pressing the reverse MODE selector button.

When the tape is set so that side A faces you, recording will be done as follows automatically according to the selected reverse mode.

	Side A only	Side A → Side B
	Side B only	Side B only

- 5 Press the REC/PAUSE button.  
\* The corresponding indicator will light up and the play direction indicators flash.
- 6 Start CD playback by pressing the corresponding disc select button, or by pressing the play/pause button if the disc is already selected.  
\* Before CD playback begins, recording automatically begins on the side of the tape now selected.





# RECORDING COMPACT DISCS

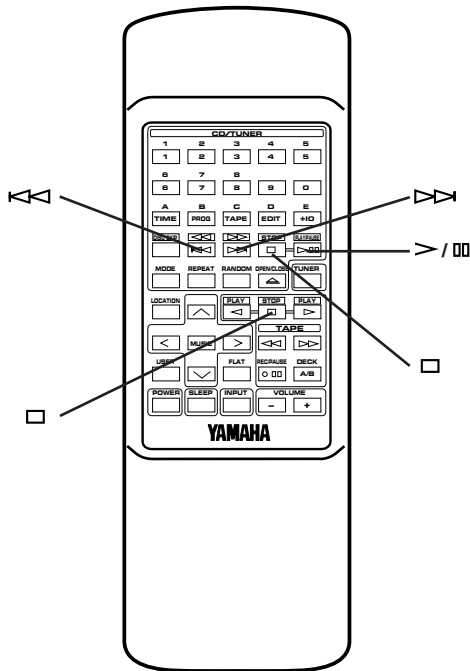
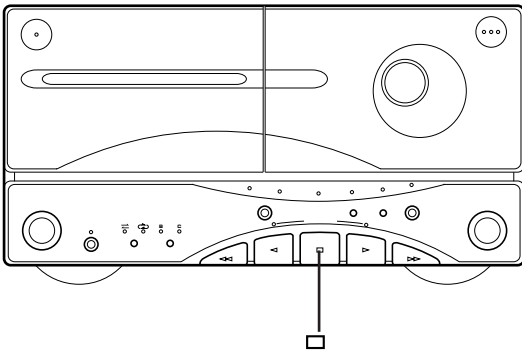
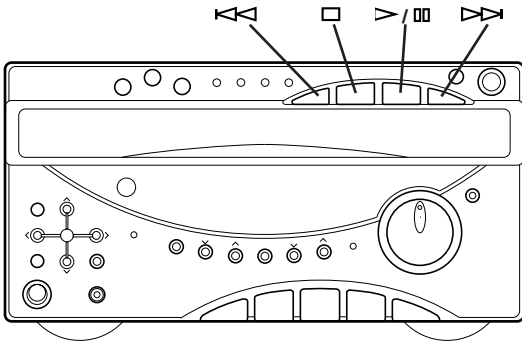

## To stop recording temporarily

- 1 Press the stop button of the CD player.
- 2 Choose the selection to be recorded next by using the or button, and then press the play/pause button of the CD player to resume recording (or simply press the track number input button on the remote control transmitter).

## To stop recording

Press the stop button of the tape deck.  
(At this time, CD playback does not stop.)

## Recording programmed tracks

Programmed tracks from one or more discs can also be recorded in the same way.

- 1 Program desired tracks from one or more discs. (Refer to page 13 for the programming procedure.)
- 2 Follow steps 2–5 on the previous page.
- 3 Press the play/pause button of the CD player.

## Notes

- During CD Synchronized Recording, when more than 4 seconds elapse between tracks, the tape will stop automatically and resume recording when the beginning of the next track is found.
- The CD Synchronized Recording will function even when the CD player is turned into random play mode.



## RECORDING COMPACT DISCS

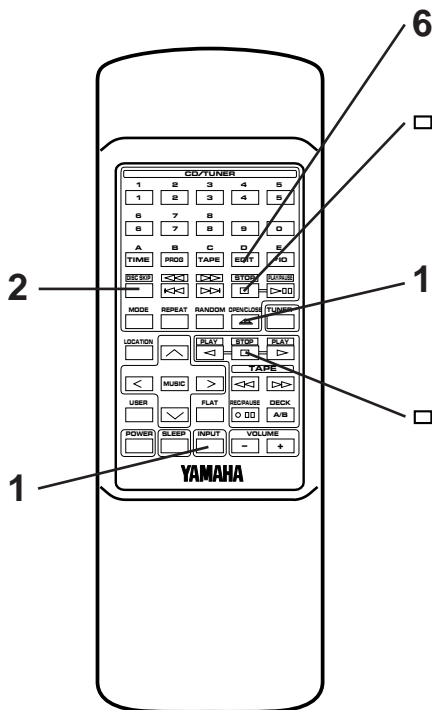
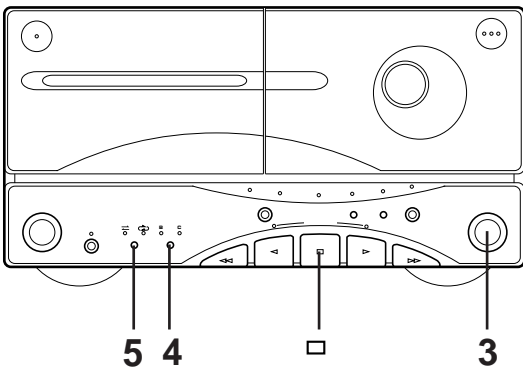
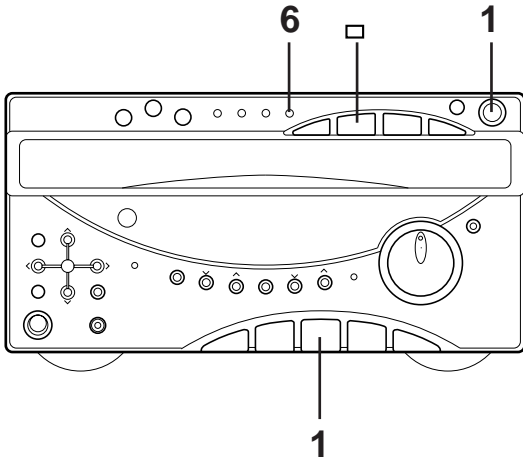

### Recording CD(s) on both sides of a tape automatically

- 1 Press the CD input selector button and load the disc to be recorded.
- 2 Select the disc by pressing the DISC SKIP button.
- 3 Load a tape into the DECK B cassette compartment.
- 4 When recording with the Dolby NR system, select the Dolby NR B or C position by pressing the DOLBY NR button. If not, set it off.
  - \* For selection of the Dolby B or C position, refer to the "Dolby B and C Type Noise Reduction" on page 23.
- 5 If the reverse mode "↺" is not selected, press the reverse MODE selector button to select it.
- 6 Press the EDIT button. ("EDIT" appears on the display.) CD playback and recording starts. Recording is carried out on side A and B of the tape continuously.
  - \* If the tape has not rewound to the end, it is rewound to the end rapidly before recording starts. Recording starts from the first part of the tape on which recording can be done.
  - \* "A O O" (or "O O B") on the display shows the side of the tape on which recording is being carried out.
  - \* When the recording on side A finishes while a track is being played back, the sound is automatically faded out, and then the recording stops. The recording on side B starts from the beginning of the same track.

#### Notes

- When this CD player is in the all disc play mode, if the tape's total possible recording time is longer than the total playing time of the selected disc, tracks on another disc are recorded continuously. In this case, as many as three discs can be recorded automatically.
- During recording, the PLAYXCHANGE button on the CD player is disabled.
- The CD player's repeat play mode will be canceled during this recording mode.

### Recording programmed tracks

Programmed tracks from one or more discs can also be recorded in the same way.

- 1 Program desired tracks from one or more discs. (Refer to page 13 for the programming procedure.)
- 2 Follow steps 3–6 described above.

#### To cancel this function

Before recording, press the stop □ button of the CD player or the tape deck.

#### To stop recording

Press the stop □ button of the tape deck. (At this time, CD playback automatically stops.)



# RECORDING COMPACT DISCS

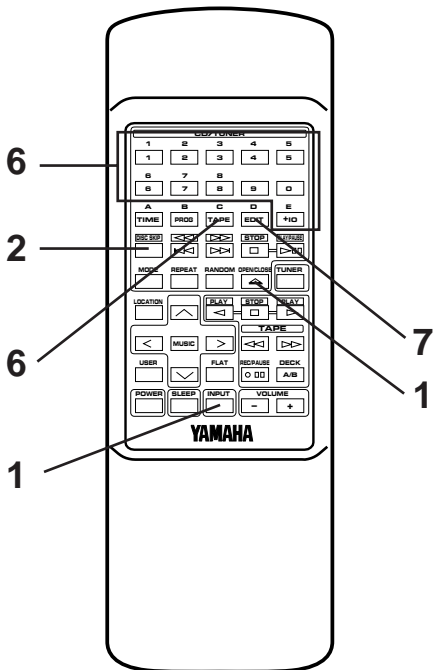
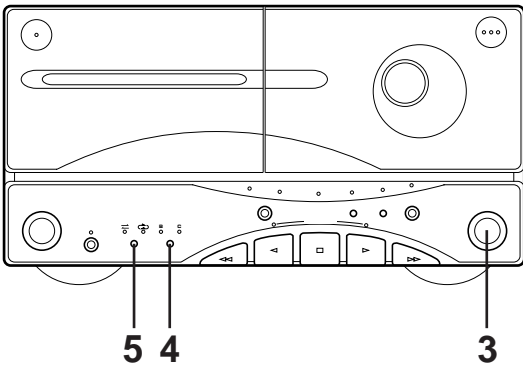
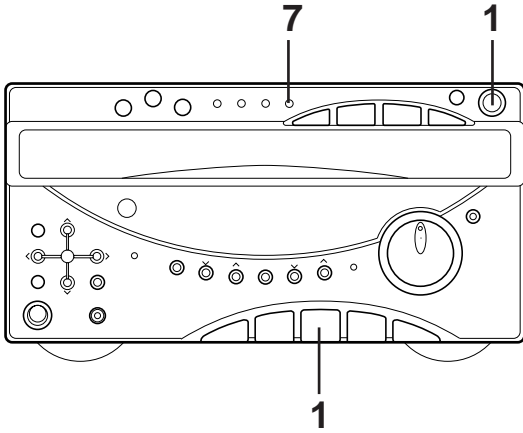

## Automatic tape-editing

This convenient feature can be used to program tracks on a disc (or discs) for recording to tape. By only memorizing the tape's total possible recording time, the unit will automatically program tracks or help you to program tracks so they will fit onto the tape with the least amount of unrecorded space remaining at each end of the tape.

### To record a disc with the order of tracks unchanged

- 1 Press the CD input selector button and load the disc to be recorded.
- 2 Select the disc by pressing the DISC SKIP button.
- 3 Load a tape into the DECK B cassette compartment.
- 4 When recording with the Dolby NR system, select the Dolby NR B or C position by pressing the DOLBY NR button. If not, set it off.
  - \* For selection of the Dolby B or C position, refer to the "Dolby B and C Type Noise Reduction" on page 23.
- 5 If the reverse mode "↶" is not selected, press the reverse MODE selector button to select it.
- 6 Press the TAPE button to select the length of the tape to be used. Whenever pressed, C-46, C-54, C-60 and C-90 appear on the display in turn, and next it returns to the normal display mode.

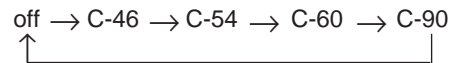

### When using tapes other than C-46, C-54, C-60 or C-90

When C-46, C-54, C-60 or C-90 is appearing on the display, input the tape length by using the track number input buttons on the remote control transmitter (Examples)

C-62: Press "6" and then "2".

C-30: Press "3" and then "0", or press "+10" three times and then "0".

- 7 Press the EDIT button. ("EDIT" appears on the display.) The following internal operations are carried out before recording is automatically started.
  - 1) Tracks on the disc are automatically divided between side A and side B. You can check the process by watching the display.
  - 2) The end part of the tape on which recording cannot be done is wound.
  - 3) CD playback and recording starts. Recording is carried out on both side A and B of the tape.



## RECORDING COMPACT DISCS

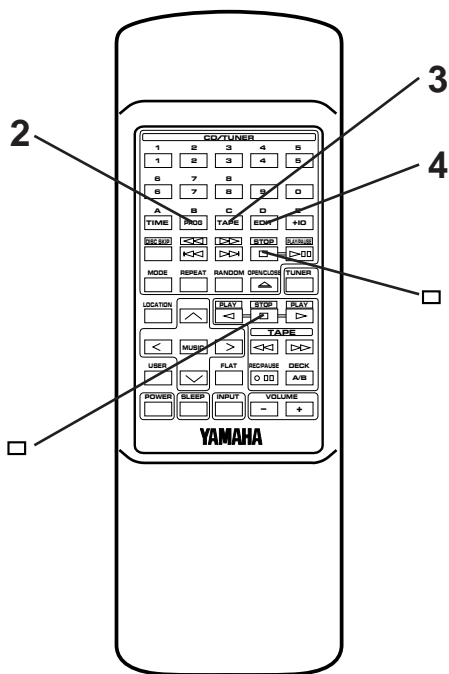
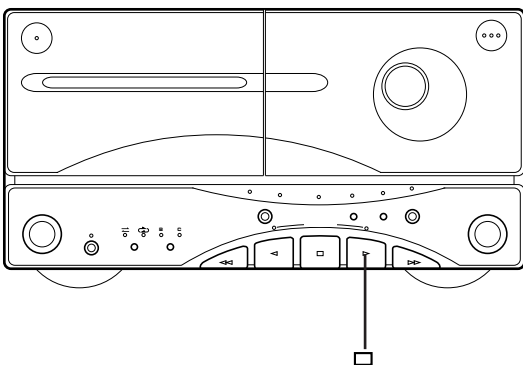
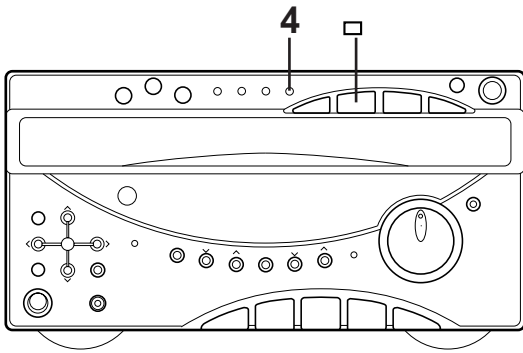

### Notes

- When this CD player is in the all disc play mode, if the tape's total possible recording time is longer than the total playing time of the selected disc, tracks on another disc are recorded continuously. In this case, as many as three discs can be recorded automatically.
- The CD player's repeat play mode will be canceled during this recording mode.

### To cancel tape-editing function

Before recording, press the stop button of the CD player or the tape deck.

### To stop recording

Press the stop button of the tape deck.  
(At this time, CD playback automatically stops.)

### To make this unit program tracks on a disc automatically so that the least amount of unrecorded space remains on the tape

- 1 Follow steps 1–6 on the previous page.
- 2 Press the PROG button.
- 3 Press the TAPE button.  
“AP A>” will light up during programming for side A, and “AP B>” will light up during programming for side B.  
  
\* After “AP B>” goes out from the display, you can check the programmed contents for side A and B respectively.  
To check, cancel or correct program data, refer to page 14.
- 4 Press the EDIT button. (“EDIT” appears on the display.)  
The recording is automatically started.



# RECORDING COMPACT DISCS

## To record programmed tracks from one or more discs

- 1** Press the CD input selector button and load a disc (or discs) on the disc table.
- 2** Follow steps 3–6 on page 27.
- 3** Press the PROG button.  
\* “PGM” and “P-01” will light up on the display, and all track numbers on the selected disc will begin flashing.
- 4** If necessary, select a desired disc by pressing the DISC SKIP button.
- 5** Select the desired track number by pressing the track number input buttons.
- 6** Repeat steps 4 and 5 to program more selections for the side A of the tape. You can select the same track again.  
\* Pressing the TIME button displays the total remaining time on the side of the tape for about 1 second, and then it is replaced by the display of the next playback order.  
\* If “ERR” appears on the display, the track number just selected cannot be programmed because there is not enough time remaining on the side A of the tape. However, at this time, if any other track number is flashing continuously on the display, you can program it instead of the unprogrammable one.
- 7** After you finish the programming for the side A, press the TAPE button.  
\* “Pu” appears on the display, then you can begin programming for side B.
- 8** Repeat steps 4 and 5 to program selections for the side B of the tape. You can select the same track again.  
\* If “ERR” appears on the display, the track number just selected cannot be programmed because there is not enough time remaining on the side B of the tape. However, at this time, if any other track number is flashing continuously on the display, you can program it instead of the unprogrammable one.
- 9** Press the EDIT button. (“EDIT” appears on the display.) The recording is automatically started.

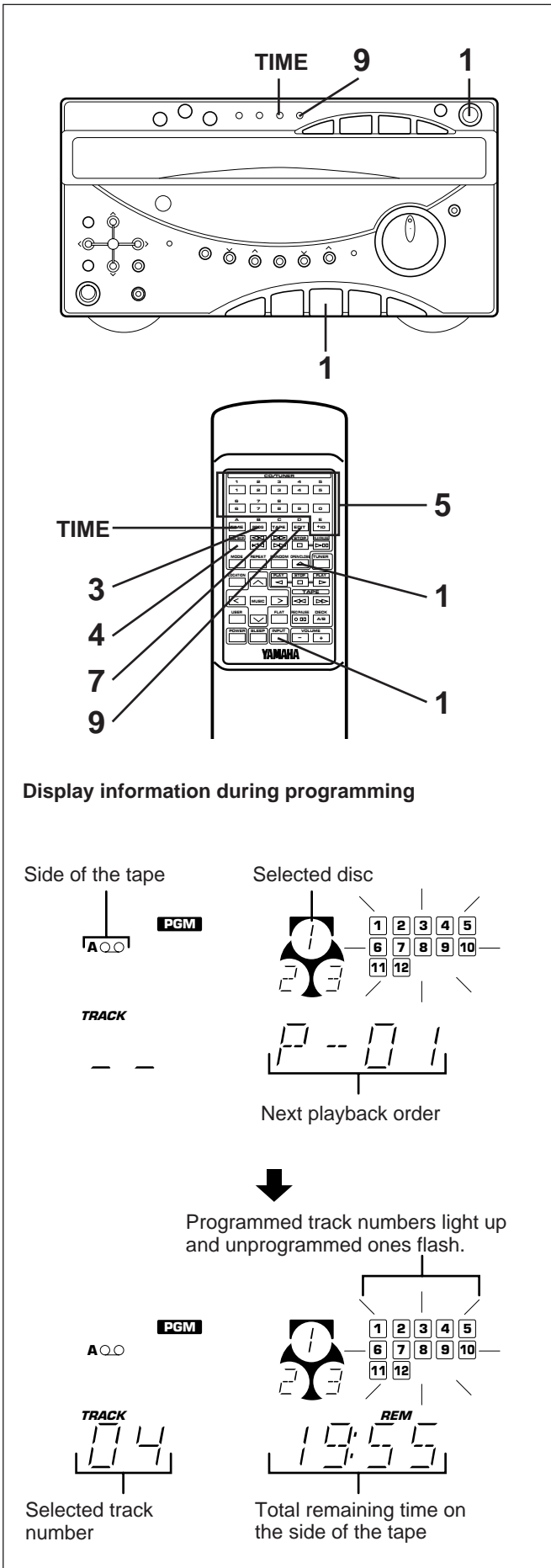

### Notes on tape-editing

- If programs are made selecting tracks from more than one disc, during recording, the PLAYXCHANGE button on the CD player is disabled.
- To check, cancel or correct program data, refer to page 14.
- The maximum number of tracks that can be programmed is 20.
- This function can be used to program up to track number 15.



## OTHER RECORDINGS

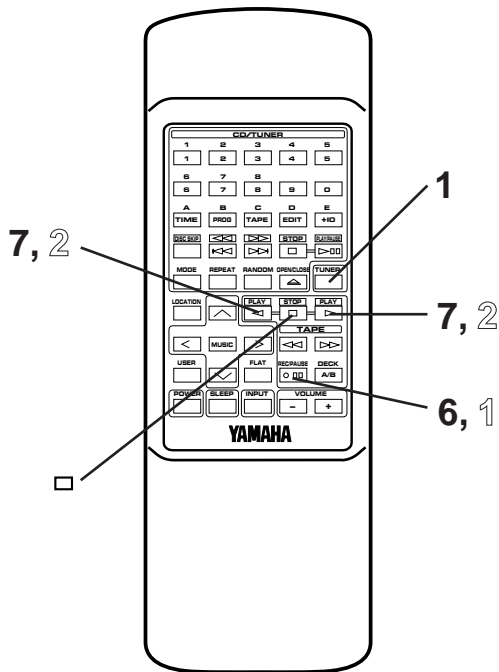
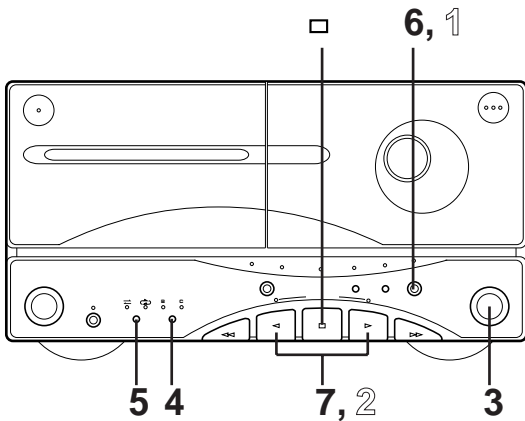
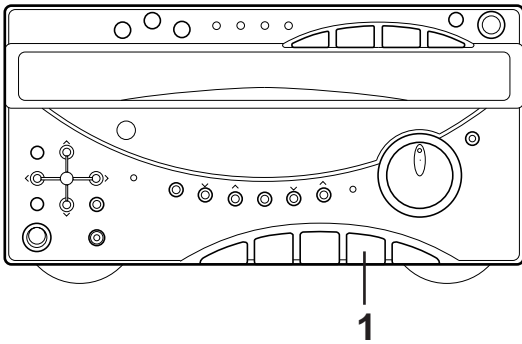

- When recording important selections, be sure to make a preliminary test to ensure that the desired source material is being properly recorded with good sound quality.
- The automatic recording level control circuit automatically controls the level of the input signal used for recording.
- Adjusting the VOLUME control and using the built-in sound field processor have no effect on the recorded sound.  
If, however, the built-in graphic equalizer is used, its effect is recorded along with the source.  
\* Music with an equalizer effect is suitable for listening to inside a car etc.
- For the tape deck, the deck which can be used for recording is the DECK B only. When recording, be sure to load a tape into the DECK B cassette compartment.

### Recording from the built-in tuner

- 1 Press the TUNER input selector button.
- 2 Tune to the desired station. (Refer to the "TUNING OPERATION" on page 17 and 18.)
- 3 Load a tape into the DECK B cassette compartment.
- 4 When recording with the Dolby NR system, select the Dolby NR B or C position by pressing the DOLBY NR button. If not, set it off.  
\* For selection of the Dolby B or C position, refer to the "Dolby B and C Type Noise Reduction" on page 23.
- 5 Select the reverse mode "↔" to record on only one side, or "↻" for continuous recording on both sides by pressing the reverse MODE selector button.
- 6 Press the REC/PAUSE button.  
\* The indicator over the button will light up and the play direction indicators will flash.
- 7 Press the play ▷ button to record on side A, or the play ◁ button to record on side B.  
\* For continuous recording on both sides, begin on side A. Recording stops automatically at the end of side B.

### To stop recording temporarily

- 1 Press the REC/PAUSE button.
- 2 To resume recording, press the play button whose indicator is flashing.

### To stop recording

Press the stop □ button.



## OTHER RECORDINGS

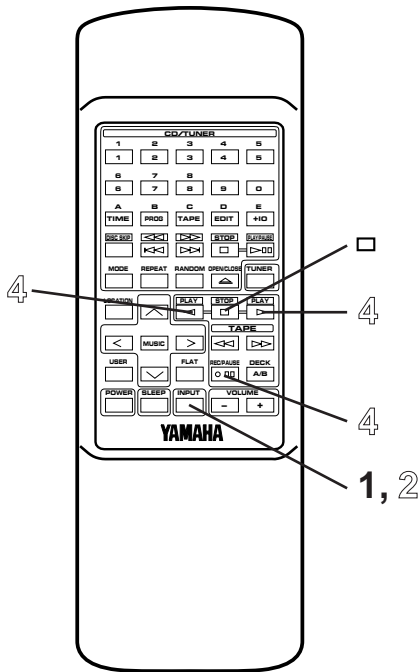
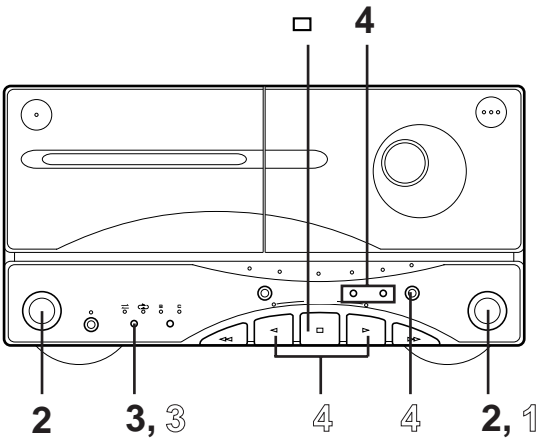
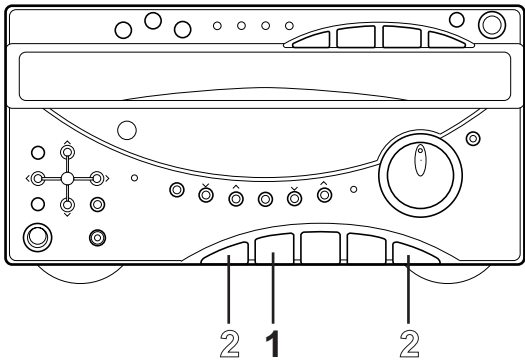

## Dubbing

- During dubbing, adjusting the VOLUME control and using the built-in sound field processor have no effect on the recorded sound.  
If, however, the built-in graphic equalizer is used, its effect is recorded along with the source.  
\* Music with an equalizer effect is suitable for listening to inside a car etc.
  - Try to use the same tape formula and length for the recording tape as for the master tape.
- 1 Press the TAPE input selector button.
  - 2 Load a prerecorded tape into the DECK A cassette compartment. Insert a blank tape into the DECK B cassette compartment.
  - 3 Select the reverse mode “↔” to record on only one side, or “↻” for continuous recording on both sides by pressing the reverse MODE selector button.
  - 4 Press the DUBBING button.  
\* Press “NORMAL” to dub at normal speed, and “HIGH” to dub at about twice the normal speed.  
\* Dubbing will begin from side A regardless of the side now selected.

### To stop dubbing

Press the stop □ button.

\* Tape A and tape B will stop at the same time.

### Note

Only tapes originally encoded with Dolby B or C NR will be dubbed onto tapes with Dolby B or C NR encoding. The setting of Dolby NR will have no effect on the recording of tape B during dubbing. However, the playback tonal quality of tape A will change according to the selected Dolby NR position.

## Erasing recorded tapes

- 1 Load the tape to be erased into the DECK B cassette compartment.
- 2 Press the AUX 1 (or AUX 2) input selector button.  
\* Make sure that there is no sound output from the external unit connected to the AUX 1 (or AUX 2) terminals on the rear of this system.
- 3 Select the reverse mode “↔” to erase only one side or “↻” to erase both sides by pressing the reverse MODE selector button.
- 4 Press the REC/PAUSE button, then press the play ► button to erase side A of the tape, or the play ◀ button to erase side B.

## GRAPHIC EQUALIZER/SOUND FIELD PROCESSOR CONTROL

The built-in graphic equalizer and sound field processor present you with the pleasure of listening to music with various sound effects.

This system provides 4 preset equalizer modes and 3 sound field modes as listed below. (For Australia, Singapore and General models, KARAOKE mode is additionally available.) You can enjoy listening to music with a desired sound effect by selecting one of these modes, or you can also enjoy various sound effect combinations by selecting an equalizer mode and a sound field mode at the same time.

The built-in 7 band graphic equalizer allows you to adjust the equalizer pattern to create an effect to your desired sound taste. (The sound field processor cannot be adjusted, however.)

Furthermore, any desired combination of an equalizer mode (or an adjusted equalizer pattern) and a sound field mode can be stored in this system as a user program. (Up to 4 user programs can be stored at the same time.)

If desired, you can link a user program with a specified input source.

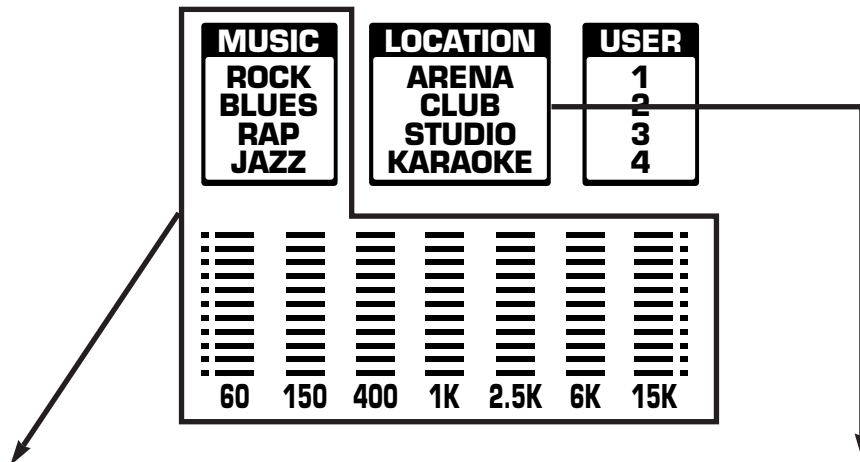

### Preset graphic equalizer modes (MUSIC)

Mode	Feature
<b>ROCK</b>	High and low frequencies are emphasized. This mode is suitable for reproducing dynamic and powerful sounds of rock music etc.
<b>BLUES</b>	Low and medium frequencies are moderately emphasized. This mode is suitable for music with a blue feeling.
<b>RAP</b>	Low and mid-high frequencies are emphasized so that vocals become well-modulated. This mode is suitable for rap music etc.
<b>JAZZ</b>	Medium frequencies for vocals, piano, sax, etc. are emphasized. High and low frequencies are also emphasized moderately.

### Sound field modes (LOCATION)

Mode	Feature
<b>ARENA</b>	This mode simulates the sound environment of a big hall with long reverberation time and many reflections of high frequencies.
<b>CLUB</b>	This mode simulates the sound environment of a jazz live house. Sounds are close and intimate.
<b>STUDIO</b>	This mode simulates the sound environment of a recording studio. Sounds are very close.
<b>KARAOKE</b>	Medium frequencies for vocals etc. are attenuated. This mode is suitable for singing karaoke by using a normal audio source with vocals. (Refer to page 37 for karaoke operation.)

\* KARAOKE mode is available on Australia, Singapore and General models only.



**Listening to the music with a preset equalizer effect**

- 1 Playback a source. (For source playback, refer to the sections beginning on page 10.)
- 2 Press the MUSIC button once or more so that the name of a desired mode appears on the preset equalizer mode indicator.
  - \* Whenever you press the MUSIC button, the preset mode changes and is displayed as follows.

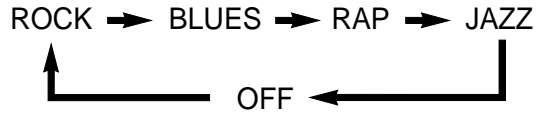

\* The equalizer pattern of the selected mode is shown on the graphic equalizer level indicators.

**Note**

An equalizer effect is also be recorded along with a source.

**Listening to the music with a sound field effect**

- 1 Playback a source. (For source playback, refer to the sections beginning on page 10.)
- 2 Press the LOCATION button once or more so that the name of a desired mode appears on the sound field mode indicator.
  - \* Whenever you press the LOCATION button, the mode changes and is displayed as follows.

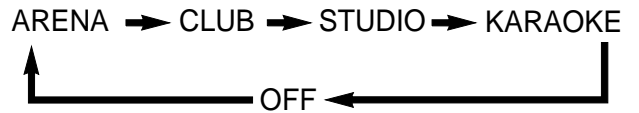

**Note**

Sound field effect cannot be recorded along with a source.

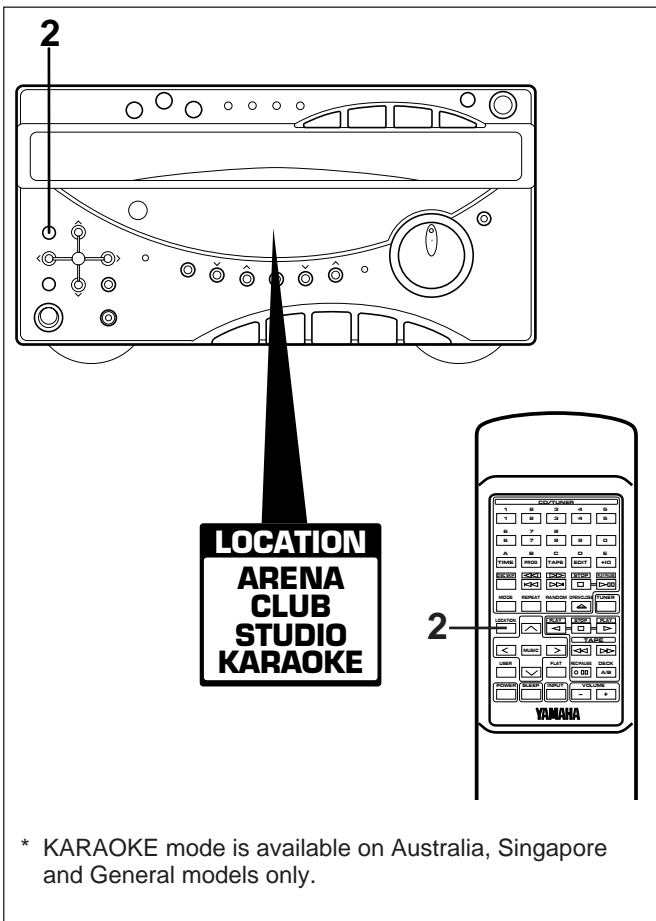
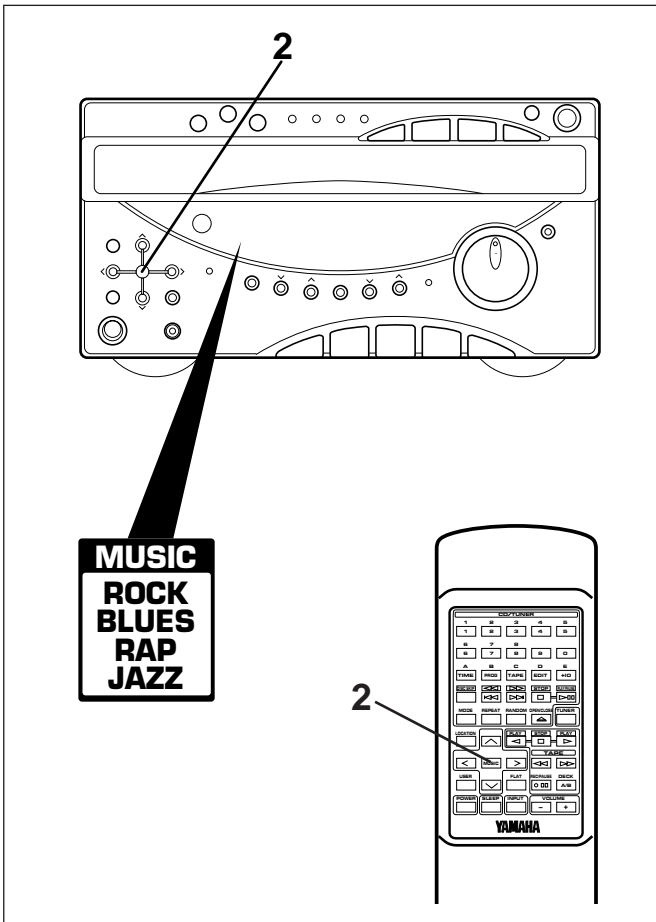

## Adjusting the graphic equalizer for your desired sound taste

The 7 band graphic equalizer allows you to adjust the level for each frequency band.

\* Make adjustment by monitoring the equalizer level indicators on the display.

- 1 Playback a source. (For source playback, refer to the sections beginning on page 10.)
- 2 Press the equalizer control < or > button once or more to select the frequency band to which you will adjust the level.
  - \* The selected frequency band is shown on the display.
  - \* The scale bar of the selected frequency band on the graphic equalizer level indicators will flash.
- 3 Press the equalizer control ^ or v button once or more to adjust the level.
- 4 In the same way, make adjustment for other frequency band.

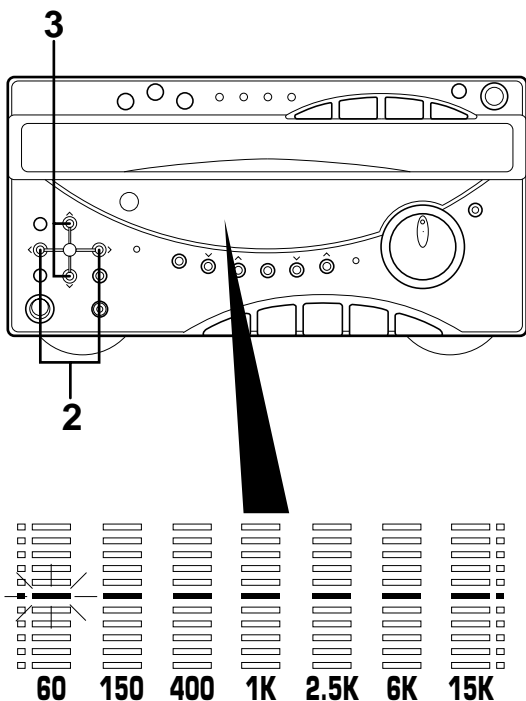

## Turning the equalizer to “flat” (the state with no equalization applied)

There are two ways as follows:

- Press the FLAT button on the remote control transmitter.
  - \* Pressing the FLAT button once more will restore the pattern which had been selected before it was turned to “flat”.
- Press the MUSIC button and the LOCATION button on the front panel at the same time.

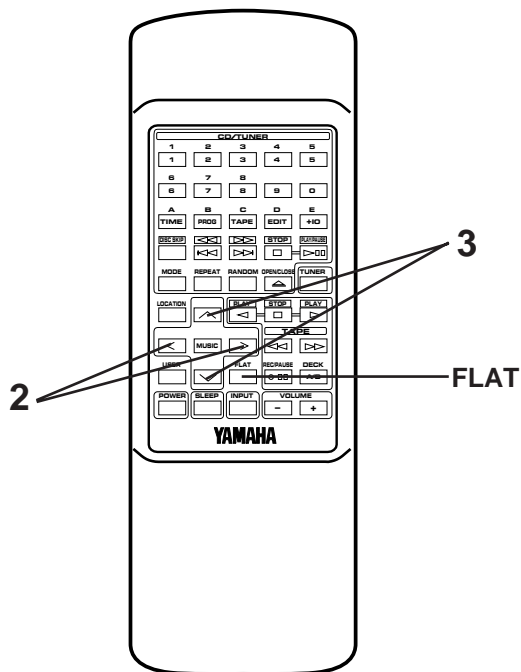

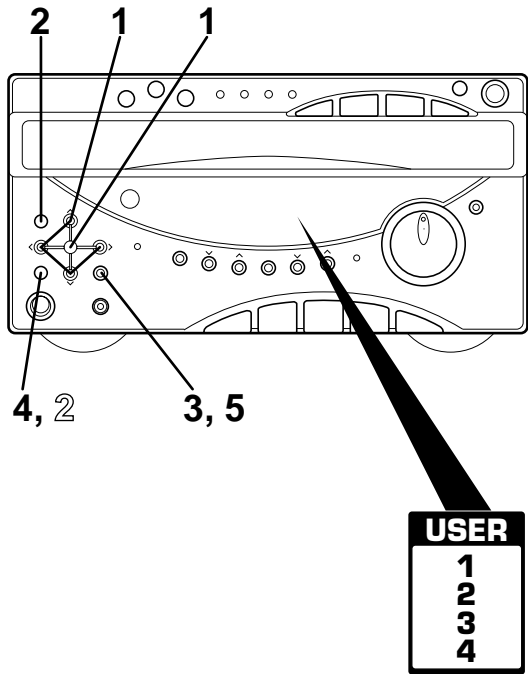

## Storing your own programs

Your favorite pair of any equalizer mode (or an equalizer pattern of your own adjusting) and any sound field mode can be stored as a user program. Up to 4 pairs can be stored as desired.

### To store

- 1 Select a desired equalizer mode by pressing the MUSIC button.  
\* If desired, adjust the equalizer as you prefer by using the equalizer control buttons.
- 2 Select a desired sound field mode by pressing the LOCATION button.
- 3 Press the user program MEMORY button.  
\* "1" will flash on the user program number indicator and the MEMORY indicator will flash for about 5 seconds.
- 4 Select the user program number (1, 2, 3 or 4) to which you will store the selected modes by pressing the USER button once or more before "1" stops flashing.  
\* Whenever you press the USER button, the user program number changes and is displayed as follows.

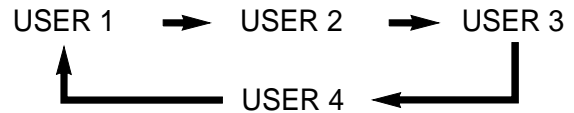

- 5 Press the user program MEMORY button before the number selected in step 4 stops flashing.

\* In the same way, store other pairs to other three user positions.

\* It is also a good idea to store only an equalizer pattern of your own adjusting (without storing any sound field mode).

### Notes

- A new program can be stored in place of the former one.
- In step 4 or 5, if the user program number indicator stops flashing before operation, return to step 3.

### To recall a user program

- 1 Playback a source. (For source playback, refer to the sections beginning on page 10.)
- 2 Press the USER button once or more so that the user program number you want to recall lights up.  
\* Whenever you press the USER button, the user program number changes and is displayed as follows.

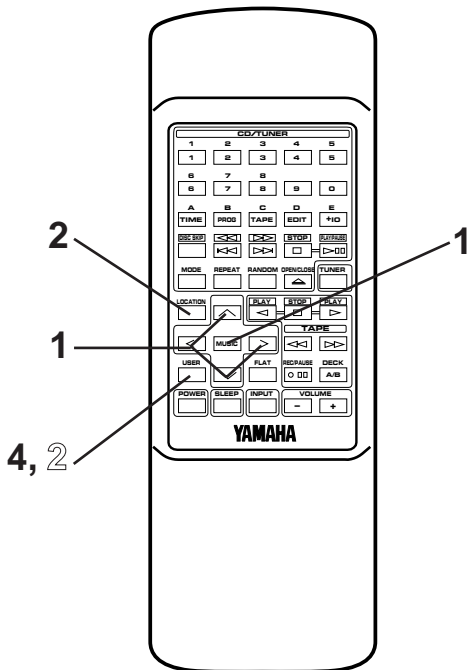
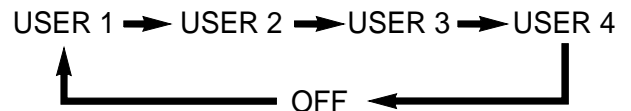

## Linking a user program to a specified input source

If a user program is linked with a specified input source, when the source is selected, the user program operates automatically. Each of the four user program can be linked with each different input source.

### To link

- 1 Recall a user program which you had stored in advance, by pressing the USER button once or more. (Refer to the previous page for storing a user program.)
- 2 Press the user program MEMORY button.
- 3 Press the input selector button whose input source you want to link with the selected user program.
  - \* The display changes as follows:

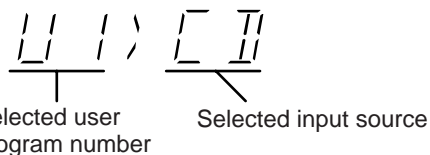

\* For the meaning of each symbol appearing on the display, see the list on the left.

- 4 Press the user program MEMORY button.

The selected user program and input source are linked by this method.

### Note

By this function, when listening to an input source, the linked user program operates automatically. If desired, however, you can cancel its operation or switch to a different user program or any equalizer/sound field mode.

### To cancel the linkage of a user program and an input source.

- 1 Press the user program MEMORY button.
- 2 Press the input selector button whose linkage with a user program you want to cancel.
- 3 Press the USER button once or more so that "U0" appears on the display.
- 4 Press the user program MEMORY button.

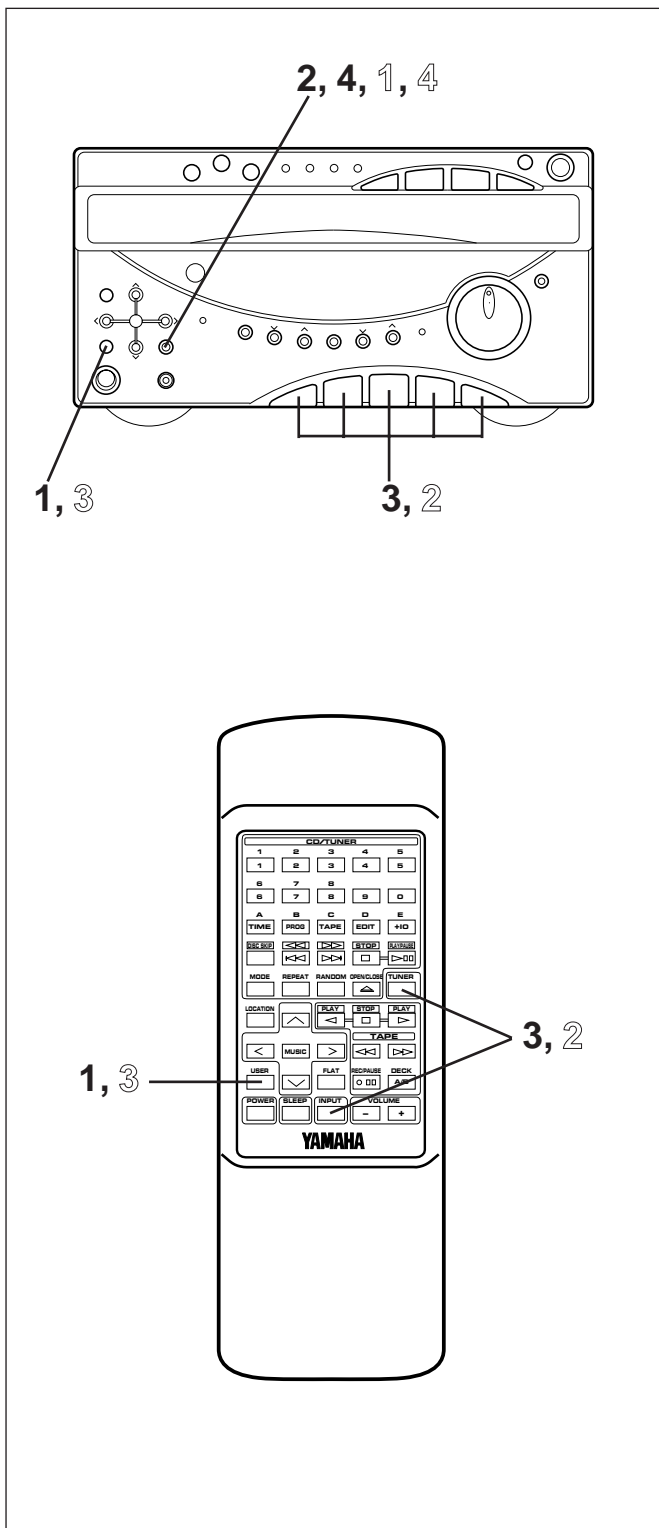

Symbol	Meaning	Symbol	Meaning
U0	No selection	A2	AUX 2
U1	USER 1	TU	TUNER
U2	USER 2	CD	CD
U3	USER 3	TA	TAPE
U4	USER 4	A1	AUX 1

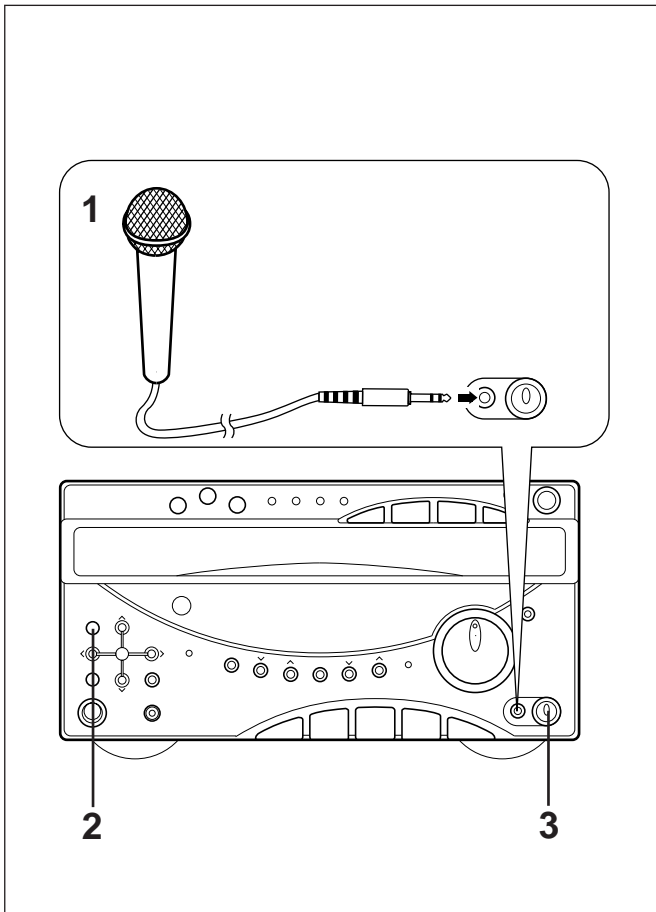

### Singing karaoke

This system allows you to enjoy singing karaoke by using not only a karaoke source without vocals but also any normal audio source with vocals.

- 1** Connect the microphone to the MIC jack on the front panel.
- 2** Playback a source. (For source playback, refer to the sections beginning on page 10.)

#### **When using a normal audio source with vocals**

Press the LOCATION button once or more so that "KARAOKE" appears on the sound field mode indicator. The sound level of vocals is automatically attenuated. (Refer to page 32 and 33 for details.)

- 3** While singing, adjust the mixing level of singing voice by turning the MIC MIXING level control.

#### **To restore the attenuated vocal sound level**

Press the LOCATION button so that "KARAOKE" disappears from the display.

#### **Note**

There may be a case that vocals cannot be attenuated effectively according to a source (monaural source etc.).

## HOW TO USE THE BUILT-IN TIMER

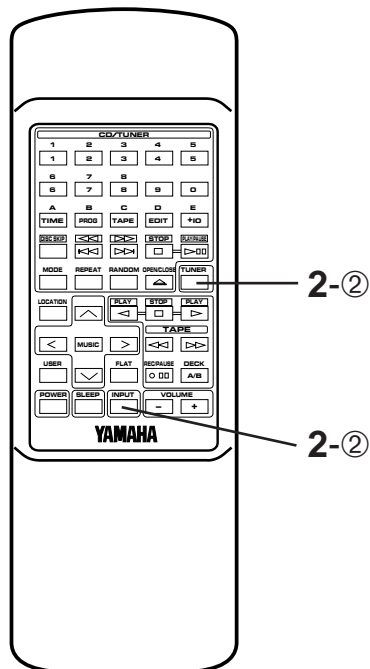
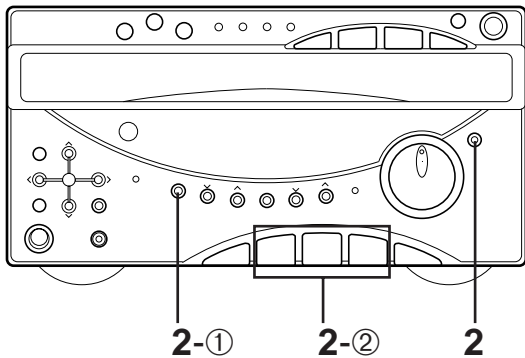

## Timer play

By using the built-in timer, you can set the time when the unit turns on and a source begins playing automatically, and the time when the unit turns off automatically.

- 1 Prepare the source to be played.

### For tuner:

Tune in to the station you will listen to.

### For tape deck:

Load a tape into the cassette compartment.  
(If tapes are loaded in both the compartments, tape A takes priority of tape B, and is played back by the timer play.)

### For CD player:

Load a disc on the disc table. If more than one disc are loaded on the disc table, select the disc by using the disc select buttons or the DISC SKIP button.

- 2 Press the DISPLAY button.  
Whenever the DISPLAY button is pressed, the display mode changes as follows.  
At each mode, make a setting for the timer play, referring to the setting procedure described below.

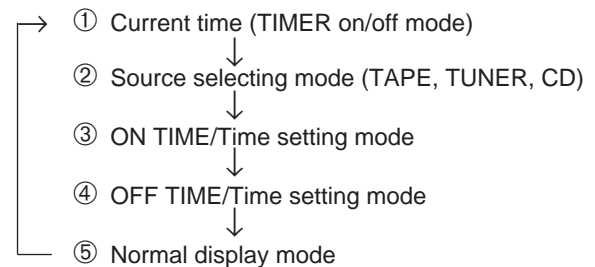

\* The display mode will be changed to the next mode after about 8 seconds elapse automatically. If the mode is changed before the setting is completed, call the mode again by pressing the DISPLAY button once or more.

### Setting procedure:

- ① **At the display of current time**  
Check to be sure that the current time is correct, and press the TIMER button so that "TIMER" appears on the display.
- ② **At source selecting mode**  
Select the source (TAPE, TUNER or CD) to be played by pressing the corresponding input selector button.  
\* If "TUNER" is selected, soon it is changed to the frequency display mode. In this mode, you can select the station to listen to with the timer play by using the BAND button, A/B/C/D/E button and PRESET ^/∨ buttons.

## HOW TO USE THE BUILT-IN TIMER

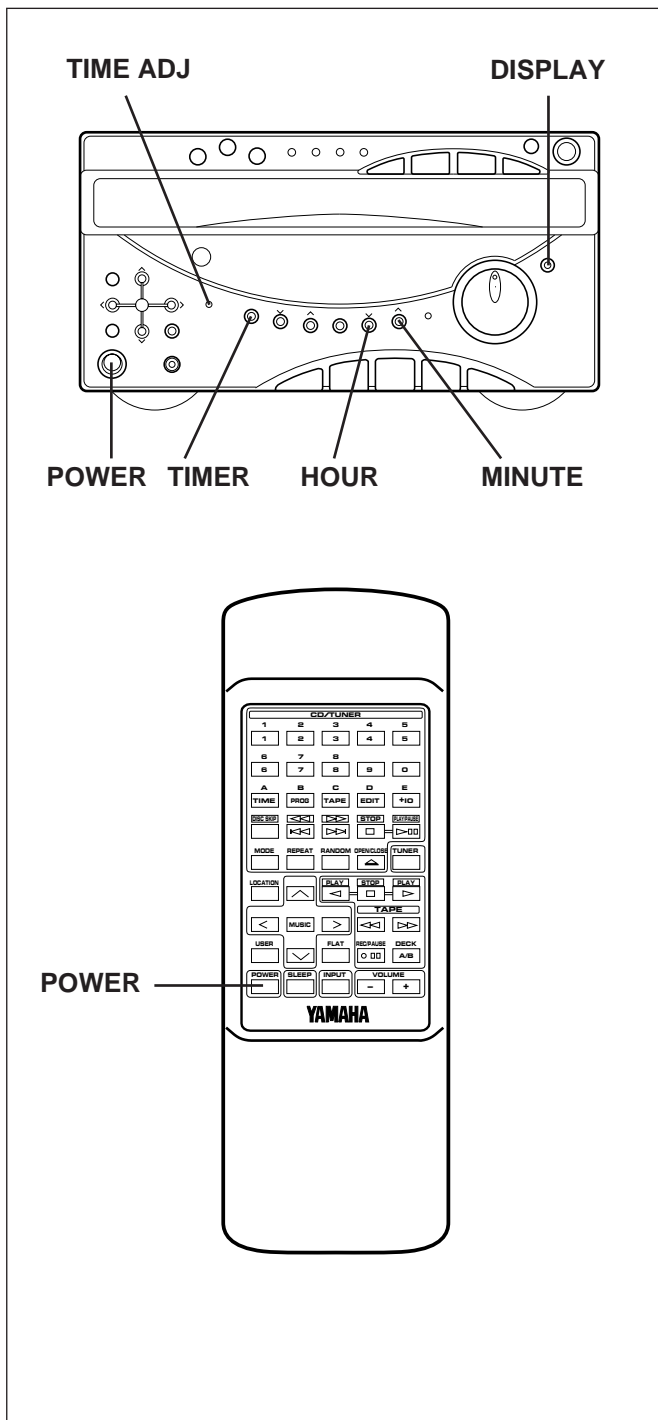

③ **At ON TIME/time setting mode**  
 ["ON TIME" appears on the display, and soon it is changed to a time setting mode.]  
 Set to the time when you want to begin the timer play by using the HOUR button and the MINUTE button.

④ **At OFF TIME/time setting mode**  
 ["OFF TIME" appears on the display, and soon it is changed to a time setting mode.]  
 If necessary, set to the time when you want to finish the timer play (to turn this unit off) by using the HOUR button and the MINUTE button. Even if you do not set the time, it has already been set so that the timer play finishes after 1 hour.

\* The TIMER button functions also in the time (ON TIME or OFF TIME) setting mode.

**3** If you will not use this unit until the timer play begins, turn the power off by pressing the POWER switch or the TIMER button.

### Note

If a timer play setting is made and the power is not turned off, the source set for the timer play will begin playing when the time comes in place of the source played at that time.

### To cancel the timer play setting

After the timer play is finished, press the DISPLAY button to call the current time. While the current time is displayed, press the TIMER button so that "TIMER" goes out from the display.

If it is not canceled, the system will be turned on at the same time every day, so it can be used as an alarm. However, if you will be out at that time, cancel the timer play setting.

\* Unless the AC supply lead is unplugged or there is a power failure for more than 5 minutes, the time set on the timer will be retained until it is reset.

### How to make time setting in the ON TIME or OFF TIME mode

#### For the hour:

Press the HOUR button to change the hour to a higher value. Press and hold to change continuously. To change the hour to a lower value, while pressing the TIME ADJ button, press the HOUR button.

#### For the minute:

Use the MINUTE button and operate it in the same way as you did to change the hour.

## HOW TO USE THE BUILT-IN TIMER

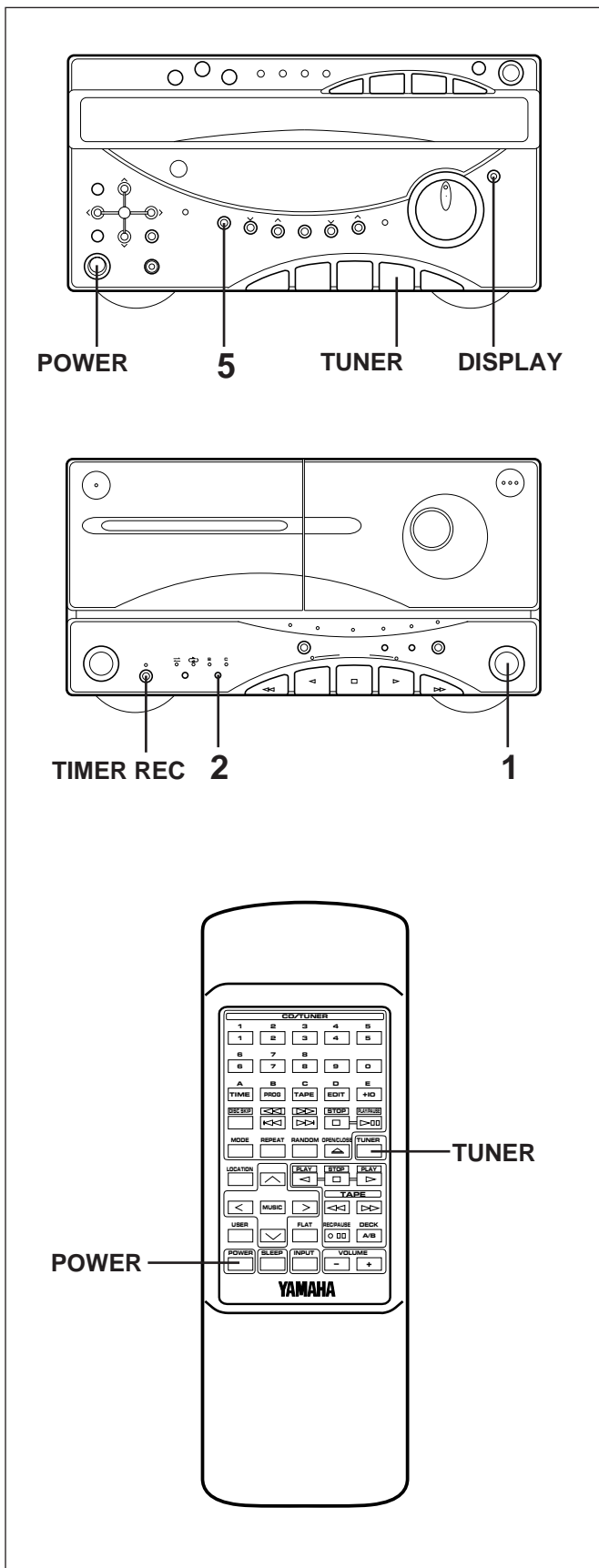

### Timer recording (To record a tuner program)

- 1 Load a blank tape into the DECK B cassette compartment.
- 2 If desired, change the setting of the reverse mode and the Dolby NR position.
- 3 Tune to the station of which program you want to record.
- 4 Follow step 2 of the "Timer play" on page 38 and 39.

- \* In step ②, press the TUNER input selector button, and then press the TIMER REC button. ("REC" will flash on the display and the indicator over the TIMER REC button will light up.)
- \* In step ③, set the time when you want to begin the timer recording.
- \* In step ④, set the time when you want to finish the timer recording.

- 5 Press the TIMER button.  
(The power will be turned off automatically.)

- \* If the normal listening mode (the state which had been selected before you began setting the timer recording) is restored before you press the TIMER button, select and follow either of the two methods below.
  - Press the DISPLAY button, and then press the TIMER button. (The power is still on.)
  - Press the POWER switch to turn the power off, and then press the TIMER button. (The power is turned off.)

#### To confirm the timer time setting

Press the DISPLAY button.

#### To cancel the setting of timer recording

Press the DISPLAY button once or more so that "REC" flashes on the display. While "REC" is flashing, press the TIMER REC button.

(The indicator over the button will go out.)

- \* Unless the AC supply lead is unplugged or there is a power failure for more than 5 minutes, the time set on the timer will be retained until it is reset.

#### Note

When the timer recording is finished, the timer setting is automatically canceled to avoid repeating timer recording of the same setting.



## HOW TO USE THE BUILT-IN TIMER

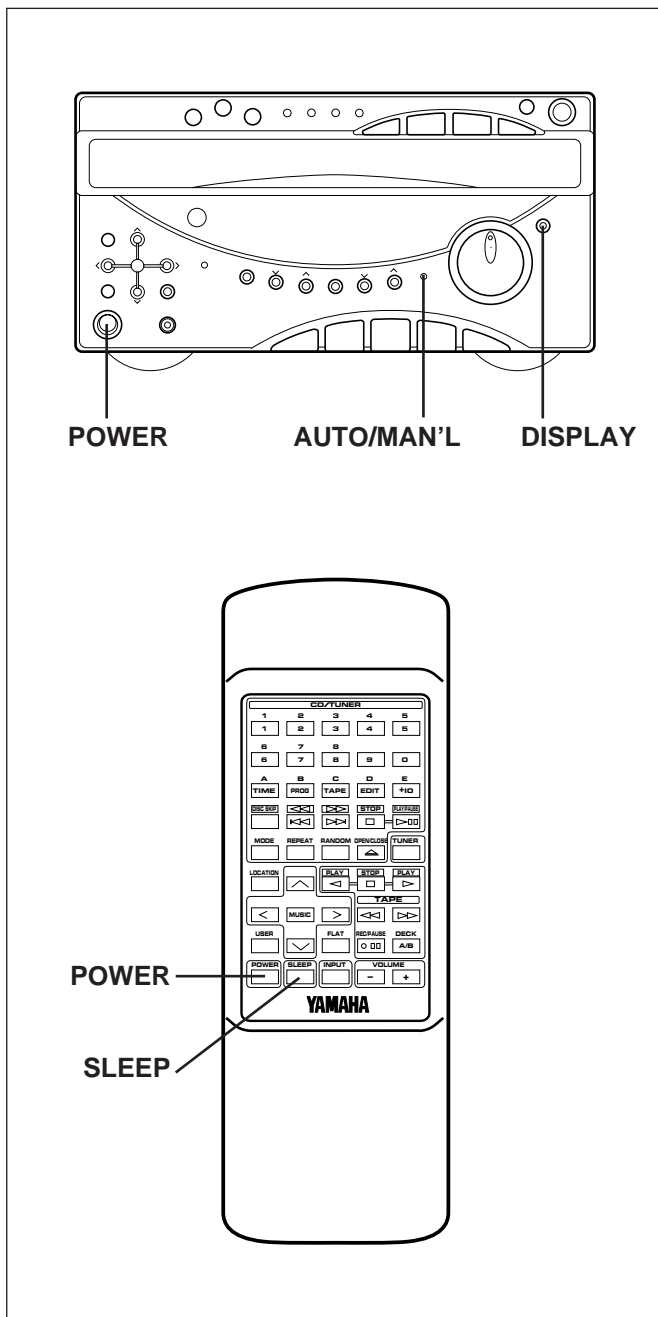

### Sleep timer operation

This unit can be turned off automatically.

- 1 Play the desired sound source.
- 2 Press the SLEEP button. "SLEEP" appears on the display, and soon it is replaced by "2h00m".
- 3 Press the SLEEP button repeatedly until the desired sleep time appears on the display. The display will change as described below. [Time is displayed by the hour (h) and the minute (m).]

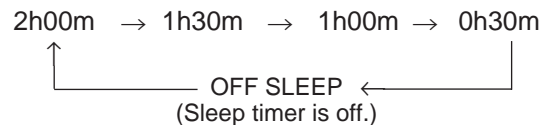

- \* The original display mode will resume about 4 seconds after the selection is made.
- \* The SLEEP indicator will light up to indicate that the sleep timer is on.

- 4 The unit will turn off automatically when the selected sleep time has passed.

#### To confirm the sleep time setting

Press the SLEEP button once. "SLEEP" appears on the display, and soon it is replaced by the remaining time of the selected sleep time.

#### To change the sleep time

While the SLEEP indicator is being illuminated, press the SLEEP button repeatedly until the desired time appears.

#### To stop the sleep timer operation

Press the POWER switch, or press the SLEEP button repeatedly until "OFF SLEEP" appears on the display. (The SLEEP indicator will go out.)

#### To set the sleep time using front panel buttons

First press the DISPLAY button to display the current time. Within 7 seconds, press the AUTO/MAN'L button. Whenever the AUTO/MAN'L button is pressed, the sleep time changes.

### Using the timer and the sleep timer at the same time

- 1 Prepare timer play. (See page 38 and 39.)
  - \* Do not turn the power of this unit off after the timer setting is finished.

- 2 Press the SLEEP button and set the sleep time.

When the sleep timer operation finishes, the timer will function to turn the source on at the preset time.

#### Note

Do not make the timer time setting so that the timer will start during sleep timer operation. (Since sleep timer operation has priority, the timer will not operate.)

## CONNECTING EXTERNAL UNITS

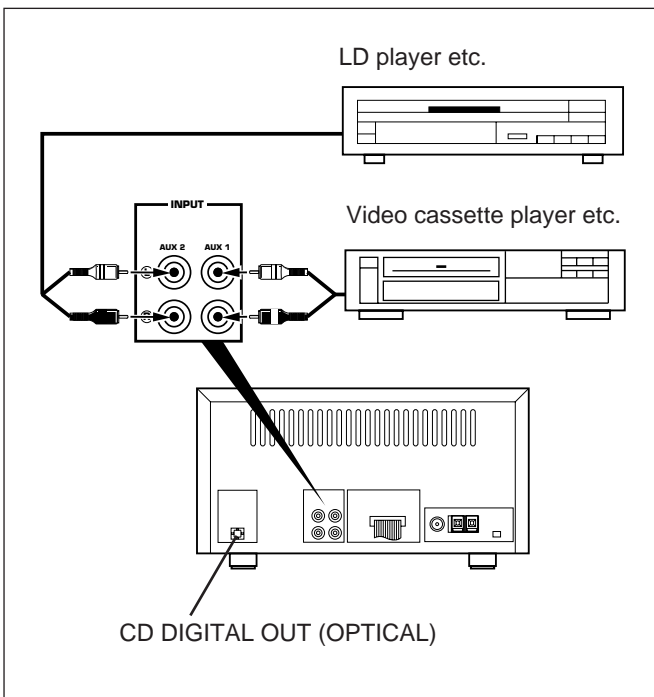

### CD DIGITAL OUT (OPTICAL) terminal on the rear panel of TCD-GX5

This system is equipped with an optical terminal to output CD's digital signals. This is available to record CD on a mini disc recorder etc. directly.

## Other audio units

This system has two sets of auxiliary input (AUX 1 and AUX 2) terminals to allow you to connect up to two external units such as a video cassette player, LD player, etc. to this system.

### To connect an external unit to the AUX 1 terminals

Connect the audio output cords of the external unit to the AUX 1 terminals on the rear of this system.

Make connections correctly so that the "L" (left) channel is connected to "L" and the "R" channel to "R".

### To listen to the source sound from the unit connected to the AUX 1 terminals

- 1 Press the AUX 1 input selector button.
- 2 Operate the unit connected to the AUX 1 terminals.

\* Its audio source can be recorded by this system's tape deck.

In the same way, connect another unit to the AUX 2 terminals.

## MAINTENANCE

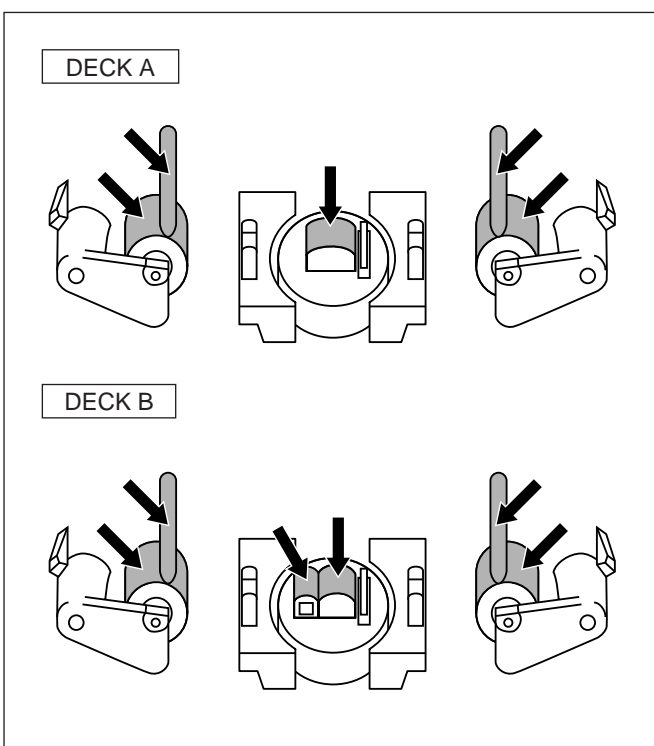

## Internal care

- Dirty heads, capstans and pinch rollers can cause poor sound and tape jams. Clean these parts with a cotton swab moistened with commercially available head/pinch roller cleaner or isopropyl alcohol, or with a commercially available cleaning tape.
- After long use, the deck's heads and capstans may become magnetized, causing poor sound. Demagnetize these parts once every 30 hours of playing/recording time by using a commercial tape head demagnetizer. Read the demagnetizer's instructions carefully before use.

## External care

- Periodically clean the surfaces of this system, especially the top panel of KMA-GX5 to prevent the ventilation holes from being blocked with dust etc.
- Do not use chemically treated cleaning cloths or other chemicals. (See "Precautions".)

## TROUBLESHOOTING

If your unit fails to operate normally, check the following points to determine whether the fault can be corrected by the simple measures suggested. If it cannot, or if the fault is not listed in the SYMPTOM column, disconnect the power cord and contact your authorized YAMAHA dealer or service center for help.

Should be service required, the servicer will need both two pieces (TCD-GX5 and KMA-GX5).

	SYMPTOM	CAUSE	REMEDY
AMPLIFIER/TUNER	No power even if the POWER switch is pressed.	AC supply lead is not plugged in.	Plug in the AC supply lead.
	No sound from one speaker	Loose speaker connections.	Connect properly.
	No sound from speakers.	Internal protection circuit is functioning.	Unplug the AC supply lead from the wall AC outlet, and then plug in again.
	Excessive static in FM broadcasts.	Interference from starting motor of nearby car.	Position the FM antenna as high and as far away from nearby roads as possible. Connect using a coaxial cable.
		Interference from thermostat of nearby electrical appliance.	
	Noise increases during stereo broadcasts.	Antenna input is too weak due to obstructions or excessive distance from broadcasting station.	Check antenna connections. Install a multi-element type FM antenna if possible.
	Stereo broadcasts are noisy and STEREO indicator blinks on and off.	Insufficient antenna input.	Install an antenna appropriate for the electric field strength of your area.
	Cannot select preset stations.	Preset memory has been erased.	Reprogram memory presets.
	Buzzing or static during AM (LW or MW) broadcasts.	Interference from source such as lightning, fluorescent lights, electric motors or thermostat of nearby electrical appliance.	Problem is difficult to eliminate but can be lessened by grounding MW/LW (AM) loop antenna.
		TV or microprocessor is being used nearby.	Move away from TV or microprocessor.
	AM (LW or MW) broadcast sensitivity is poor.	Radio signal is weak or antenna is not properly connected.	Properly connect MW/LW (AM) loop antenna.
			Change orientation of MW/LW (AM) loop antenna.
			Install an external MW/LW (AM) antenna.
Can't set timer.	Current time is not set.	Set current time.	
This unit will not operate properly.	The internal microcomputer has been frozen by an external electric shock (lightning, excessive static electricity, etc.) or power supply with low voltage.	Unplug the AC supply lead from the wall AC outlet, and then plug in again after about one minute.	
CD PLAYER	Play does not begin even if disc is loaded.	Disc is upside down.	Load disc label side up.
		Disc is dirty.	Clean disc.
	No sound.	Input selector setting is incorrect.	Select the CD input selector button.
	Sound stops suddenly (always at same spot).	Disc is dirty.	Clean disc.
Volume set too high.		Lower volume.	
TAPE DECK	Tape won't move during playback or recording.	Slack tape wrapped around pinch roller.	Take up slack with a pencil before using.
	Can't record.	Erasure prevention tab is broken off.	Replace tape or cover erasure prevention hole with cellophane tape.
		Head is dirty.	Clean heads.
	Sound is distorted or fades out.	Head is dirty.	Clean heads.
		Head has become magnetized.	Demagnetize heads with head eraser.
		Tape is worn.	Replace tape.
	Poor sound quality.	Selected Dolby NR position is not proper.	Select the position matching that used when tape was recorded.
	Stereo balance is poor.	Head is dirty.	Clean heads.
	Excessive noise.	Head is dirty.	Clean heads.
		Head has become magnetized.	Demagnetize heads with head eraser.
		Tape is worn.	Replace tape.
	Tape travel stops in middle of playback or recording.	Slack tape coming out of cassette shell.	Take up slack by turning reels with a pencil.
		Tape is creased or torn.	Replace with new tape.
Endless tape is being used.		Don't use endless tapes.	
Can't find the beginning of desired selections on tape.	Silent gaps between selections are too short.	The function of searching for the beginning of desired selections won't operate unless the silent gaps between selections are at least four seconds long.	
	Excessively soft passages in middle of selections.		
	Conversation etc. is recorded.		
REMOTE CONTROL	Remote control doesn't work.	Batteries are dead.	Replace batteries.
		Remote control is too far away or is being used at incorrect angle.	Use within 6 m and 60° radius.
		Direct sunlight or lighting (of an inverter type of fluorescent lamp etc.) is striking the remote control sensor of the main unit.	Change position of the main unit.
	TV functions strangely when the remote control is used.	Remote control is being used near TV set with a remote control sensor.	Relocate this unit away from the TV or cover TV's remote control sensor.

## SPECIFICATIONS

As a part of policy of continuous improvement, YAMAHA reserves the right to make design and specification changes for product improvement without prior notice. The performance specification figures indicated are nominal values of production units.

### ■ Amplifier section

<b>Minimum RMS Output Power per Channel</b>	
6 ohms, 1 kHz, 0.1% THD	35W+35W
6 ohms, 1 kHz, 10% THD	
[U.S.A., Canada, General and Singapore models only]	
	50W+50W
<b>DIN Standard Output Power per Channel [Europe model only]</b>	
6 ohms, 1 kHz, 1% THD	40W
<b>IEC Power [Europe model only]</b>	
6 ohms, 1 kHz, 0.1% THD	35W
<b>Input Sensitivity/Impedance</b>	
AUX	175 mV/39 k-ohms
<b>Headphone Output Impedance</b>	68 ohms
<b>Total Harmonic Distortion (1 kHz)</b>	
AUX to SP OUT (17.5W/6 ohms)	0.08%
<b>Signal-to-Noise Ratio (IHF-A Network)</b>	
AUX (Input Shorted)	
[U.S.A., Canada, U.K. and Europe models]	90 dB
[Australia, Singapore and General models]	75 dB
<b>Graphic Equalizer Characteristics</b>	
(60 Hz, 150 Hz, 400 Hz, 1 kHz, 2.5 kHz, 6 kHz, 15 kHz)	
	±10 dB

### ■ Tuner section

<b>Tuning Range</b>	
<b>FM</b>	
[U.S.A. and Canada models]	87.5 to 107.9 MHz
[Australia, U.K., Europe, General and Singapore models]	87.5 to 108.0 MHz
<b>AM (MW)</b>	
[U.S.A., Canada, General and Singapore models]	530 – 1,710 kHz
[Australia, U.K. and Europe models]	531 – 1,611 kHz
<b>LW</b>	
[U.K. and Europe models only]	153 – 288 kHz
<b>Usable Sensitivity</b>	
<b>FM (75 ohms)</b>	
(30 dB S/N Quieting, 1 kHz, 100% mod.)	
[Except Europe model]	1.2 µV (12.8 dBf)
(DIN, Mono, S/N 26 dB) [Europe model]	1.5 µV
<b>AM (MW)</b>	280 µV/m
<b>LW</b>	560 µV/m

### ■ CD player section

<b>Type</b>	3 DISC Carousel Auto-changer
<b>Signal Readout</b>	Non-contact, 3-beam semi-conductor laser pick-up
<b>D/A Converter</b>	1-bit DAC
<b>Filter</b>	8-time oversampling digital filter
<b>Wow and Flutter</b>	Below measurable limits

### ■ Tape deck section

<b>Type</b>	Auto Reverse 4-Track 2-Channel playback/recording and playback stereo double Cassette Deck
<b>Heads</b>	PB, REC/PB : Hard Permalloy Erase : Double Gap Ferrite
<b>Motors</b>	DC servo motor x 2
<b>Wow and Flutter</b>	±0.15%, W.PEAK 0.08%, W.RMS
<b>Fast Winding Time (C-60 Tape)</b>	About 100 seconds
<b>Frequency Response (-20 dB)</b>	30 – 15,000 Hz ± 3 dB (Normal) 30 – 16,000 Hz ± 3 dB (CrO <sub>2</sub> ) 30 – 18,000 Hz ± 3 dB (Metal)
<b>Signal-to-Noise Ratio</b>	58 dB (Dolby NR OFF) 66 dB (Dolby B NR ON) 74 dB (Dolby C NR ON)
<b>Harmonic Distortion</b>	No more than 1.2%
<b>Channel Separation (Input Shorted 1 kHz)</b>	More than 40 dB
<b>Crosstalk (Input Shorted 125 Hz)</b>	More than 55 dB

### ■ Speaker section

<b>Type</b>	Active Servo Processing type
<b>Speakers</b>	16 cm (6-5/16") woofer 5 cm (1-15/16") tweeter
<b>Frequency Range</b>	70 – 20,000 Hz
<b>Sound Pressure Level</b>	86.0 dB
<b>Maximum Power Handling Capacity</b>	75W
<b>Impedance</b>	6 ohms

### ■ General

<b>Power Supply</b>	
[U.S.A. and Canada models]	AC 120V, 60 Hz
[Australia and U.K. models]	AC 240V, 50 Hz
[Europe and Singapore models]	AC 230V, 50 Hz
[General model]	AC 110/120/220/240V, 60/50 Hz
<b>Power consumption</b>	110W
<b>Dimensions (W x H x D)</b>	
TCD-GX5	280 x 150.5 x 366.4 mm (11" x 5-15/16" x 14-7/16")
KMA-GX5	280 x 150.5 x 355.5 mm (11" x 5-15/16" x 14")
NX-GX5	200 x 300.0 x 249.0 mm (7-7/8" x 11-13/16" x 9-13/16")
<b>Weight</b>	
TCD-GX5	5.0 kg (11 lbs. 0 oz.)
KMA-GX5	6.2 kg (13 lbs. 10 oz.)
NX-GX5	3.0 kg (6 lbs. 10 oz.) x 2